

ASS-4009
ASS-4009/T
ASS-4009/WF
ASS-4009/T/WF

ASS-5009
ASS-5009/T
ASS-5009/WF
ASS-5009/T/WF

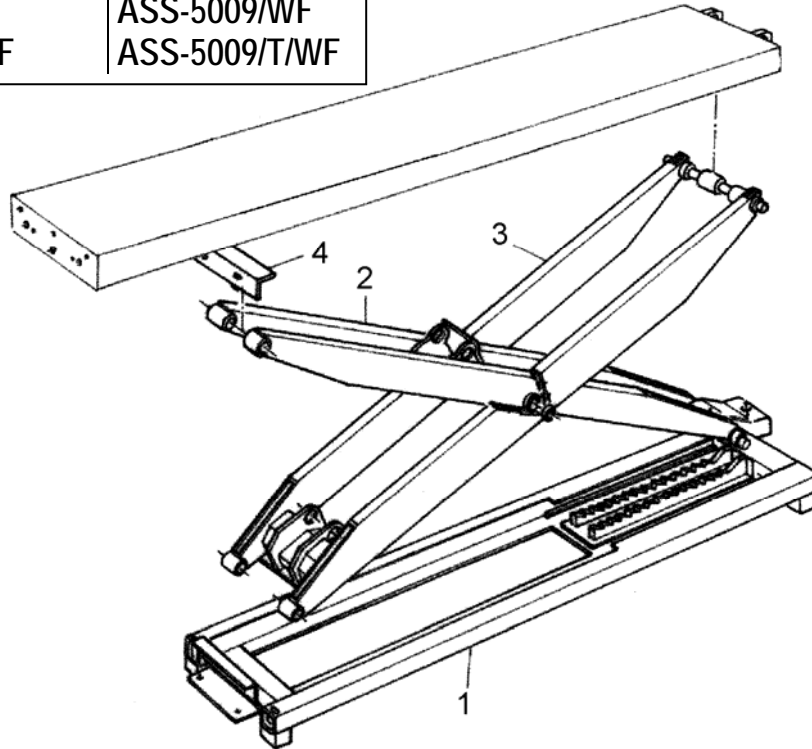

POS	BESTEL NUMMER ORDER NUMBER BESTELLUNGSNUM	DESCRIPTION	BESCHREIBUNG	OMSCHRIJVING
1.	OS10-029	BASE FRAME		GROND FRAME
2.	OS10-030	INNERARM		SCHAARBEEN INTERN
3.	OS10-031	EXTERNAL ARM		SCHAARBEEN EXTERN
4.	OS10-038	CONNECTION		BEVEST.PLAAT SCHAARBEEN

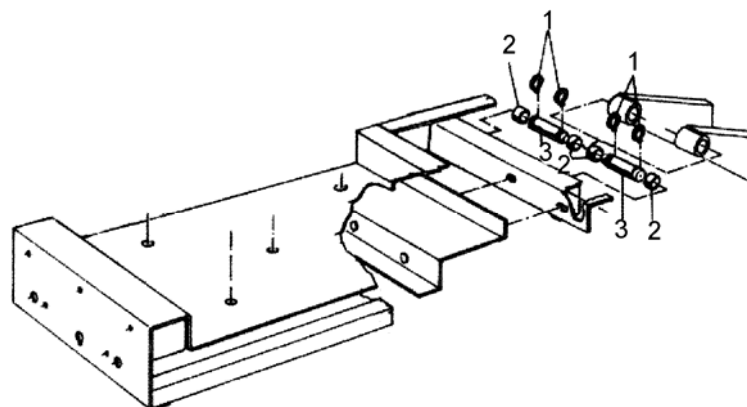

POS	BESTEL NUMMER ORDER NUMBER BESTELLUNGSNUM	DESCRIPTION	BESCHREIBUNG	OMSCHRIJVING
1.	FRD471M30	SEEGER		SEEGERRING
2.	OS30-0005	SELF LUBR.BUSHING KU 30x30		ZELFSMERENDE BUS 30x30
3.	OS20-0040	ARM FIXING PIN		BEVEST.PEN SCHAARBEEN

ASS-4009	ASS-5009
ASS-4009/T	ASS-5009/T
ASS-4009/WF	ASS-5009/WF
ASS-4009/T/WF	ASS-5009/T/WF

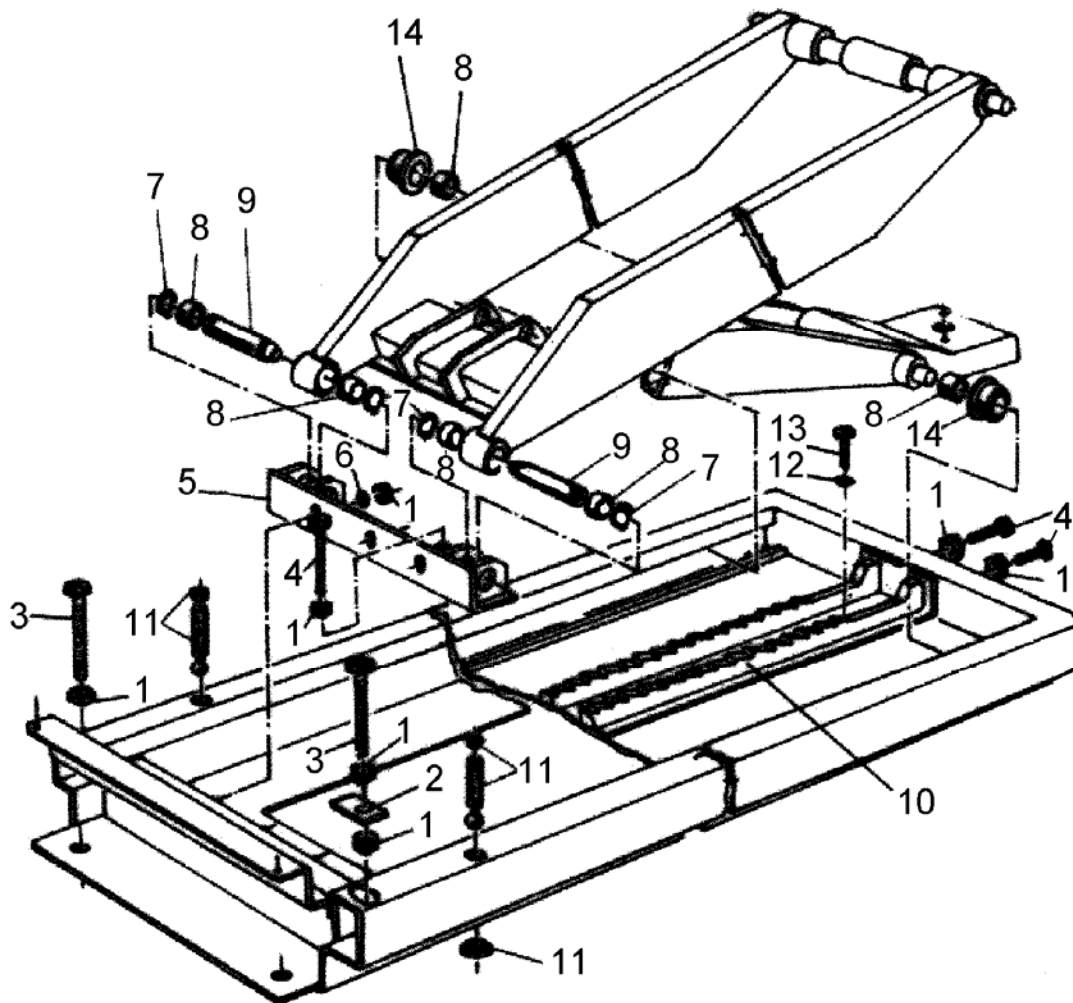

POS	BESTEL NUMMER ORDER NUMBER BESTELLUNGSNUM	DESCRIPTION	BESCHREIBUNG	OMSCHRIJVING
1.	FND934M14	NUT		MOER
2.	OS10-109	SELF LEVERING SYSTEM BRACKET		MONTAGE PLAAT (AUT.SYNS.)
3.	FB4017M14X90	BOLT		BOUT
4.	FB4017M14X120	BOLT		BOUT
5.	OS10-037	LOWER ARM FIXING		MONTAGEPLAAT (SCHAARBEEN)
6.	FRD125M14	RING		SLUITRINGRING
7.	FRD471M30	SEEGER		SEEGERRING
8.	OS30-0005	SELF LUBR.BUSHING KU 30x30		ZELFSMERENDE BUS 30x30
9.	OS20-0040	ARMS FIXING PIN		BEVEST.PEN SCHAARBEEN
10.	OS10-039	MECHANICAL SAFETY RACK		MECH.VERTANDINGSSTRIP
11.	OS30-0080	COPMLETE SUPPORT		STELBOUT CPL.GRONDFRAME
12.	FRD125M8	RING		RING
13.	FB4017M8x16	BOUT		BOUT
14.	OS20-0049	LOWER ROLLER		LOOPWIEL BENEDEN

ASS-4009	ASS-5009
ASS-4009/T	ASS-5009/T
ASS-4009/WF	ASS-5009/WF
ASS-4009/T/WF	ASS-5009/T/WF

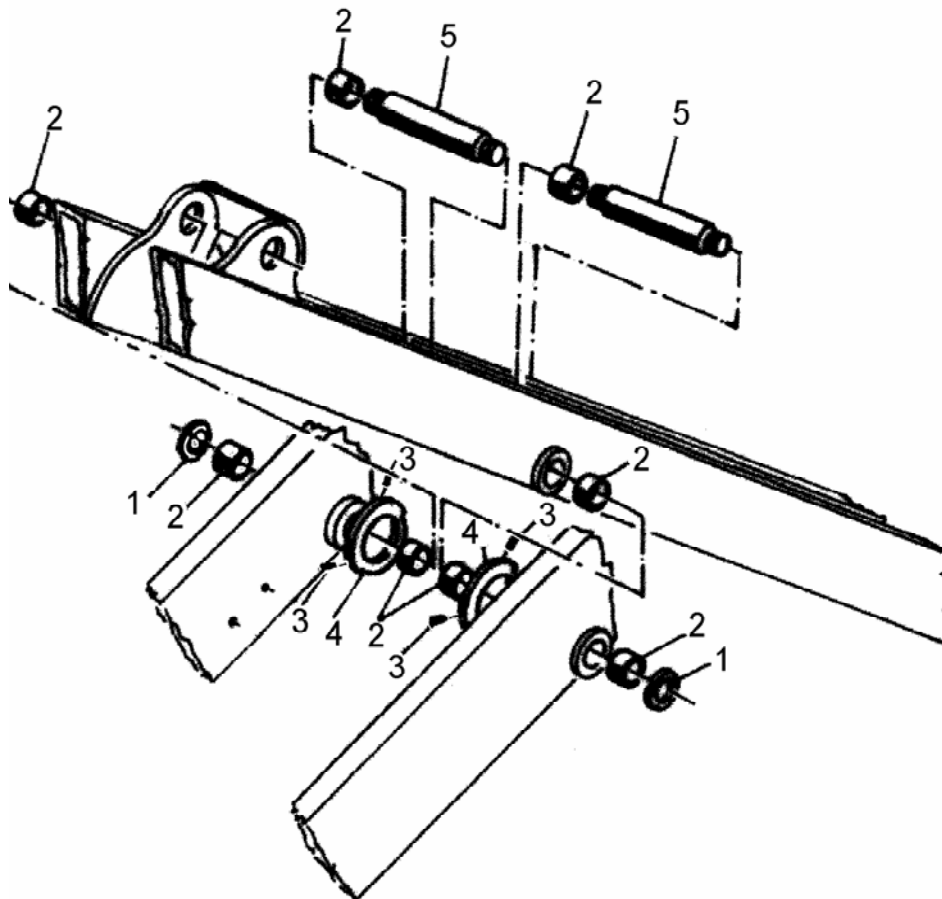

POS	BESTEL NUMMER ORDER NUMBER BESTELLUNGSNUM	DESCRIPTION	BESCHREIBUNG	OMSCHRIJVING
1.	FND985M25	SELF LOCKING NUT		ZELFBORGENDE MOER
2.	OS30-0005	SELF LUBRI.BUSHING KU 30x30		ZELFSMERENDE BUS 30x30
3.	FB4014M5X10	DOWEL		ZESKANTBOUT
4.	OS10-205	CAM		MEENEMER
5.	OS20-0041	ARMS CONNECTION PIN		VERBINDINGSPEN SCHAARBEEN

ASS-4009
ASS-5009

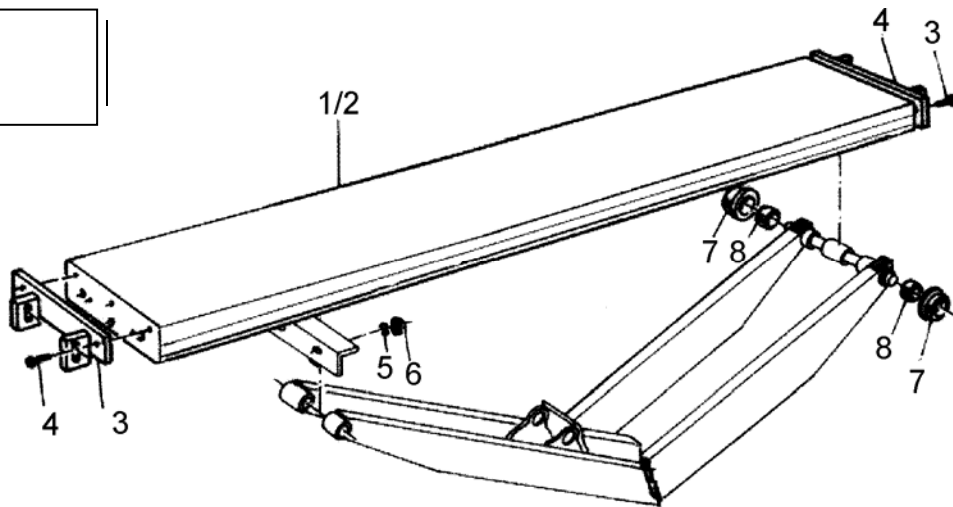

POS	BESTEL NUMMER ORDER NUMBER BESTELLUNGSNUM	DESCRIPTION	BESCHREIBUNG	OMSCHRIJVING
1a.	OS10-052	RUNAWAY P1		RIJBAAN (KAAL) P1 (4009)
1b.	OS10-052-L	RUNAWAY P1		RIJBAAN (KAAL) P1 (5009)
2a.	OS10-268	RUNAWAY P2		RIJBAAN (KAAL) P2 (4009)
2b.	OS10-268-L	RUNAWAY P2		RIJBAAN (KAAL) P2 (5009)
3.	OS10-044	BRACKET FOR SHORT RAMP		MONTAGE BEUGEL (AFRIJBEV.)
4.	FSD7991M14X30	SCREW		INBUSBOUT
5.	FRD125M14	WASHER		SLUITRING
6.	FND934M14	NUT		MOER
7.	OS20-0048	UPPER ROLLER		LOOPWIEL BOVEN
8.	OS30-0005	SELF LUBR.BUSHING KU 30x30		ZELFSMERENDE BUS 30x30

ASS-4009/WF
ASS-5009/WF

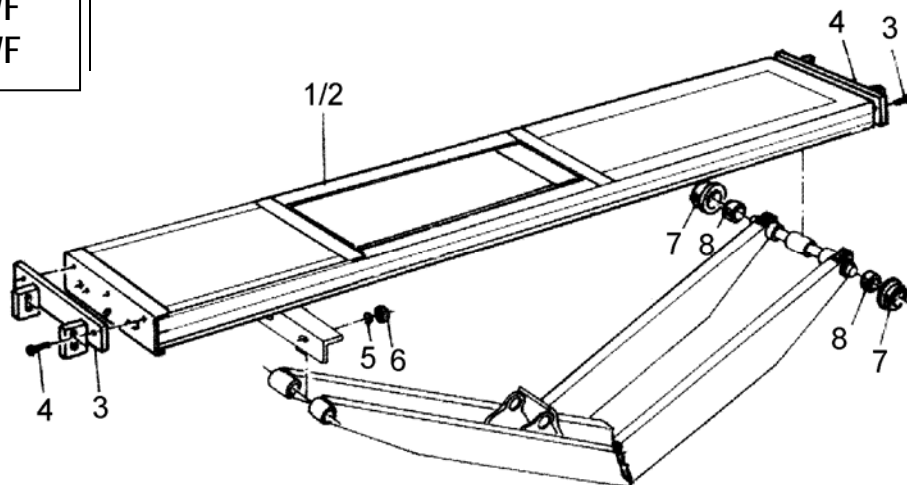

POS	BESTEL NUMMER ORDER NUMBER BESTELLUNGSNUM	DESCRIPTION	BESCHREIBUNG	OMSCHRIJVING
1a.	OS10-053	RUNWAY P1		RIJBAAN (KAAL) P1(4009/WF)
1b.	OS10-053-L	RUNWAY P1		RIJBAAN (KAAL) P1(5009/WF)
2a.	OS10-270	RUNWAY P2		RIJBAAN (KAAL) P2(4009/WF)
2b.	OS10-270-L	RUNWAY P2		RIJBAAN (KAAL) P2(5009/WF)
3.	OS10-044	BRACKET FOR SHORT RAMP		MONTAGE BEUGEL (AFRIJBEV.)
4.	FSD7991M14x30	SCREW		INBUSBOUT
5.	FRD125M14	WASHER		SLUITRING
6.	FND934M14	NUT		MOER
7.	OS20-0048	UPPER ROLLER		LOOPWIEL BOVEN
8.	OS30-0005	SELF LUBR.BUSHING KU 30x30		ZELFSMERENDE BUS 30x30

ASS-4009/T	ASS-5009/T
ASS-4009/T/WF	ASS-5009/T/WF

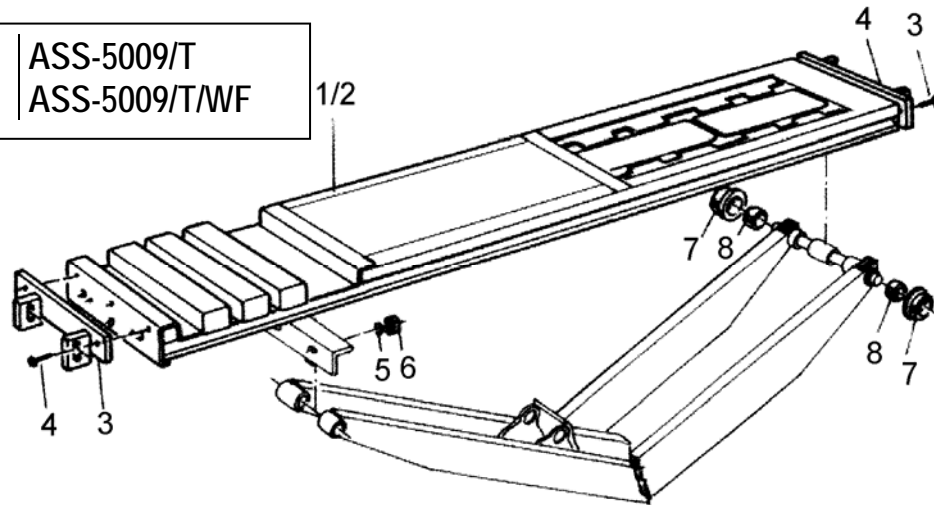

POS	BESTEL NUMMER ORDER NUMBER BESTELLUNGSNUM	DESCRIPTION	BESCHREIBUNG	OMSCHRIJVING
1a.	OS10-054	RUNAWAY P1		RIJBAAN (KAAL) P1 (4009/T)
1b.	OS10-054-L-	RUNAWAY P1		RIJBAAN (KAAL) P1 (5009/T)
1c.	OS10-055	RUNAWAY P1		RIJBAAN (KAAL) P1 (4009/T/WF)
1d.	OS10-055-L	RUNAWAY P1		RIJBAAN (KAAL) P1 (5009/T/WF)
2a.	OS10-269	RUNAWAY P2		RIJBAAN (KAAL) P2 (4009/T)
2b.	OS10-269-L	RUNAWAY P2		RIJBAAN (KAAL) P2 (5009/T)
2c.	OS10-271	RUNAWAY P2		RIJBAAN (KAAL) P2 (4009/T/WF)
2d.	OS10-271-L	RUNAWAY P2		RIJBAAN (KAAL) P2 (5009/T/WF)
3.	OS10-044	BRACKET FOR SHORT RAMP		MONTAGEBEUGEL (AFRIJBEV).
4.	FSD7991M14x30	SCREW		INBUSBOUT
5.	FRD125M14	WASHER		SLUITRING
6.	FND934M14	NUT		MOER
7.	OS20-0048	UPPER ROLLER		LOOPWIEL BOVEN
8.	OS30-0005	SELF LUBR.BUSHING		ZELFSMERENDE BUS 30x30

ASS-4009/T	ASS-5009/T
ASS-4009/T/WF	ASS-5009/T/WF

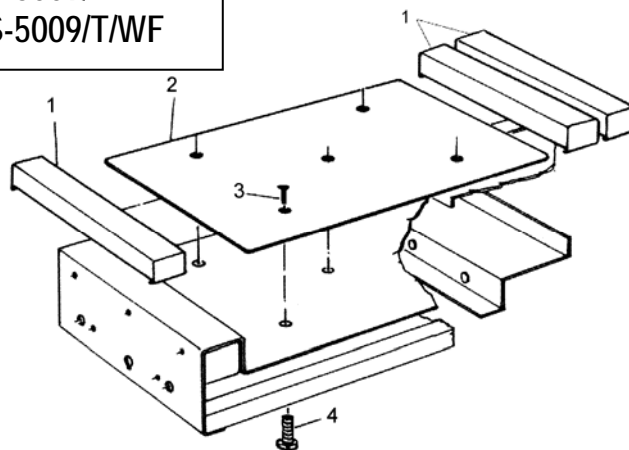

POS	BESTEL NUMMER ORDER NUMBER BESTELLUNGSNUM	DESCRIPTION	BESCHREIBUNG	OMSCHRIJVING
1.	OS10-043	FILLING LATES		OPVULSTUK UITNEEMBAAR
2.	OS10-042	ADJUSTABLE PLATE		VERSTELBARE PLAAT
3.	FSD7991M10X20	SOCKET HEAD SCREW		INBUSBOUT
4.	OS10-121	HOLED BOLT FOR PLATES		OPNAMEPLATEAU

ASS-4009/T	ASS-5009/T
ASS-4009/T/WF	ASS-5009/T/WF

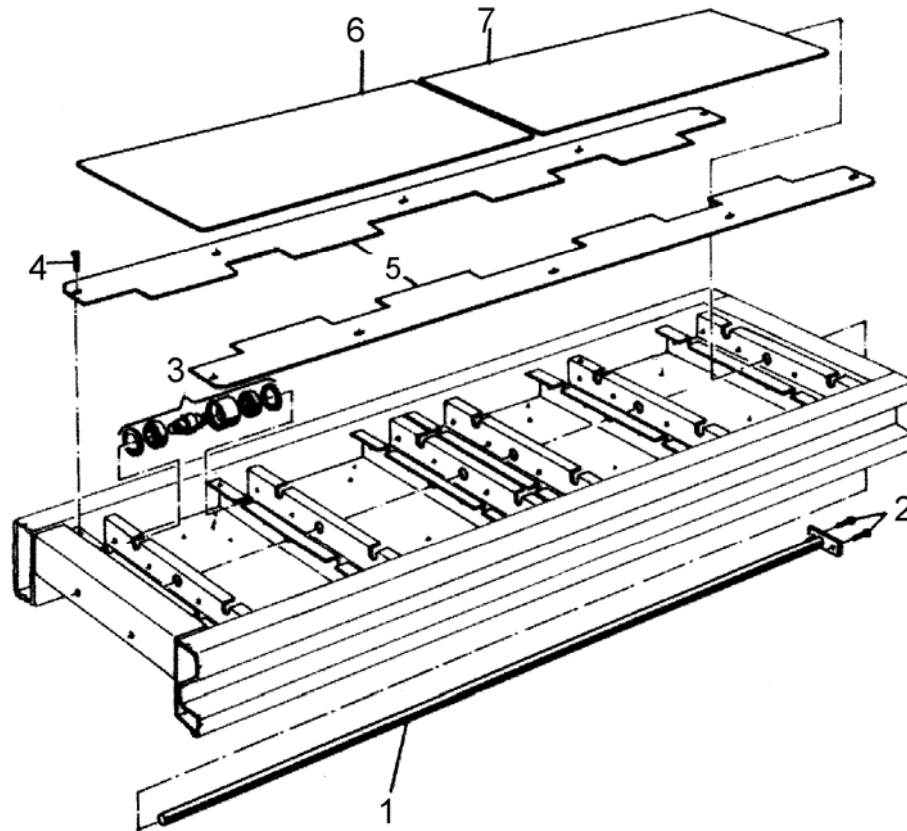

POS	BESTEL NUMMER ORDER NUMBER BESTELLUNGSNUM	DESCRIPTION	BESCHREIBUNG	OMSCHRIJVING
1.	OS10-041	SLIP PLATES FIXING PIN		BEVEST.PEN KOMP.PLATEN
2.	FSD7991M6x10	SCREWSPEI		INBUSBOUT
3.	OS20-0058	ROLLER FOR SLIDE PLATES		LOOPWIEL KOMP.PLAAT
4.	FS7380M6x16	SCREW BUTTON		INBUSBOUT
5.	OS10-074	COVER PLATES		AFDEKPLAAT KOMP.PLAAT
6.	OS10-120	SHAPED SLIP PLATE		KOMPENSATIEPLAAT ACHTER
7.	OS10-040	SLIP PLATE		KOMPENSATIEPLAAT

ASS-4009	ASS-5009
ASS-4009/T	ASS-5009/T
ASS-4009/WF	ASS-5009/WF
ASS-4009/T/WF	ASS-5009/T/WF

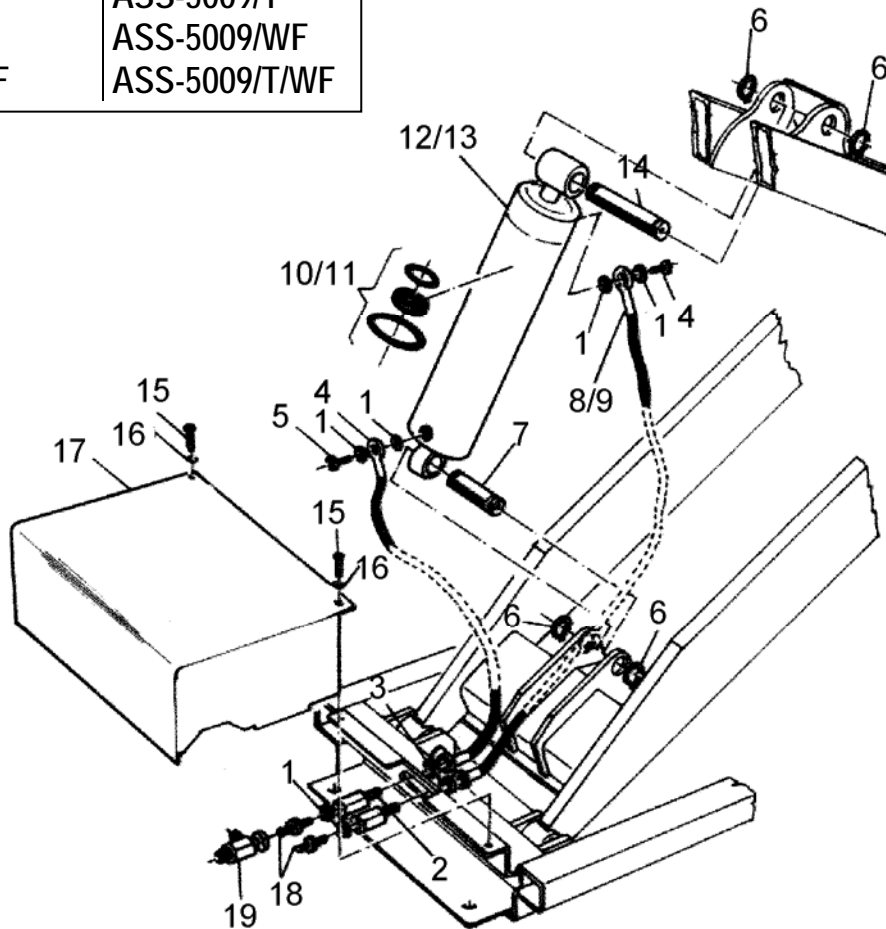

POS	BESTEL NUMMER ORDER NUMBER BESTELLUNGSNUM	DESCRIPTION	BESCHREIBUNG	OMSCHRIJVING
1.	OS40-0020	COPPER WASHER 3/8"		HYDR.KOPEREN-RING 3/8"
2.	OS20-0026	PLATE		AANSLUITBLOK/PLAAT
3.	OS20-0027	NUT FOR THROUGH PLATE		HYDR.MOER 3/8"
4.	OS40-0262	HOSE R2 AT 3/8" L=520 MM		HYDR.SLANG R2T 520 3/8"
5.	OS40-0006	HOLED BOLT 3/8"		HYDR.BANJOBOUT 3/8"
6.	FRD471M45	SEEGER		SEEGERRING
7.	OS20-0042	LOWER CYLINDER FIXING PIN		BEVEST.PEN CIL.BENEDEN
8.	OS40-0263	HOSE R2 AT 3/8" L=1120 MM P1		HYDR.SLANG R2T 1120 3/8" P1
9.	OS40-0264	HOSE R2 AT 3/8" L=1120 MM P2		HYDR.SLANG R2T 1120 3/8" P2
10.	OS40-0296	GASKET KIT P1 (D130)		REP.SET.CILINDER P1/130
11.	OS40-0297	GASKET KIT P12(D120)		REP.SET CILINDER P2/120
12.	OS40-0029	CYLINDER P1		HYDR.CILINDER P1/130MM
13.	OS40-0030	CYLINDER P2		HYDR.CILINDER P2/120MM
14.	OS20-0043	UPPER CYLINDER FIXING PIN		BEVEST.PEN CIL.BOVEN
15.	FSD912M6x20	SOCKET HEAD BOLT		INBUSBOUT
16.	FRD125M6	RING		SLUITRING
17.	OS10-036	CARTER BASE		DEKSEL (HYDR.AANSL.)
18.	OS40-0013	NIPPLES MM 3/8"		HYDR.INSTEEKNIPPEL
19.	OS40-0137	"T" CONNECTION MF 3/8"		HYDR.T STUK 3/8"

ASS-4009/WF	ASS-5009/WF
ASS-4009/T/WF	ASS-5009/T/WF

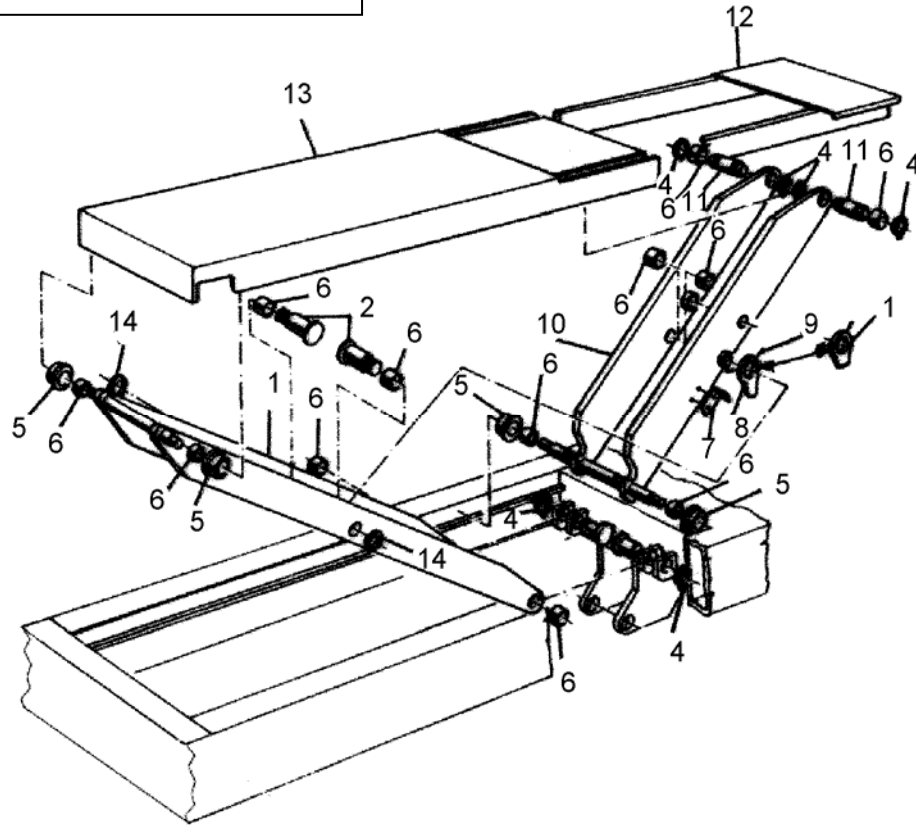

POS	BESTEL NUMMER ORDER NUMBER BESTELLUNGSNUM	DESCRIPTION	BESCHREIBUNG	OMSCHRIJVING
1.	OS10-033	EXTERNAL ARM		SCHAARBEEN EXTERN WF
2.	OS20-0046	ARMS CONNECTION PIN		BEVEST.PEN WSCHAARBEEN.WF
3.	OS20-0050	LIFT TABLE LOWER LIFTING PIN		BEVEST.PEN SCHAARBEEN.BEN.
4.	FRD471M30	SEEGER E 30 DIN 471 UNI 7435		SEEGERRING D 30
5.	OS20-0051	LIFT TABLE ROLLER		LOOPWIEL WF-SYST.
6.	OS30-0005	SELF LUBRI.BUSHING KU 30x30		ZELFSMERENDE BUS 30x30
7.	OS10-047	SENSOR BRACKET		SENSOR HOUDER
8.	OS10-048	BEVELED CAM		MEENEMER
9.	FSD913M5X10	DOWEL		STELSCHROEF
10.	OS10-032	INNER ARM		SCHAARBEEN INTERN WF
11.	OS20-0047	UPPER ARM FIXING PIN		BEVEST.PEN SCHARBEEN.BOV.
12.	OS10-035	LIFT TABLE EXTENSION		UITSCHUIFSTUK OPN.TAFEL WF
13.	OS10-034	LIFT TABLE RUNWAY		OPNAMEPLATEAU WF SYST
14.	FND985M25	SELF-LOOKING NUT M25x1.5		BORGMOER
15.	OS10-049	NOT BEVELED CAM		MEENEMER

ASS-4009/WF
ASS-4009/T/WF

ASS-5009/WF
ASS-5009/T/WF

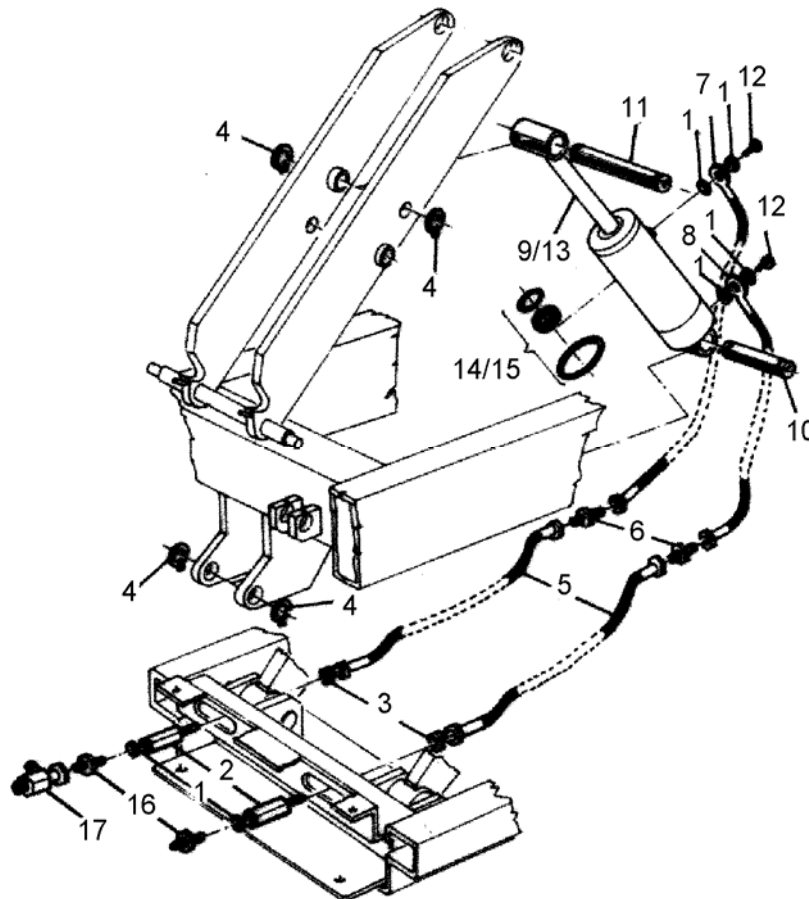

POS	BESTEL NUMMER ORDER NUMBER BESTELLUNGSNUM	DESCRIPTION	BESCHREIBUNG	OMSCHRIJVING
1.	OS40-0020	COPPER WASHER 3/8"		HYDR.KOPEREN-OPVULRING 3/8"
2.	OS20-0026	PLATE THROUGH PLATE		"RACCORDO PASSALAMIERA"
3.	OS20-0027	NUT FOR THROUG PLATE		HYDR.MOER 3/8"
4.	FRD471M45	SEEGER		SEEGERRING
5.	OS40-0261	HOSE R2 AT 3/8" L = 3450 MM		HYDR.SLANG R2T 3450 3/8"
6.	OS40-0138	NIPPLES MM 1/4"		HYDR.KOPPELSTUK 1/4"
7.	OS40-0259	HOSE R2 AT 3/8" L = 3520 MM		HYDR.SLANG R2T 3520 3/8"
8.	OS40-0260	HOSE R2 AT 3/8" L = 3150 MM		HYDR.SLANG R2T 3150 3/8"
9.	OS40-0126	CYLINDER LIFT TABLE P1		HYDR.CILINDER WF-P1/110
10.	OS20-0044	LOWER CYLINDER FIXING PIN		BEVEST.PEN CIL.BENEDEN
11.	OS20-0045	HUPPER CYLINDER FIXING PIN		BEVEST.PEN CIL.BOVEN
12.	OS40-0006	HOLED BOLT 3/8"		HYDR.BANJOBOUT 3/8"
13.	OS40-0127	CYLINDER LIFT TABLE P2		HYDR.CILINDER WF-P2/100
14.	OS40-0298	GASKET KIT P1 (D110)		REP.SET WF CILINDER P1/110
15.	OS40-0299	GASKET KIT P2 (D100)		REP.SET WF CILINDER P2/100
16.	OS40-0013	NIPPLES MM 3/8"		HYDR.INSTEEKNIPPEL
17.	OS40-0137	"T" CONNECTION MMF 3/8"		HYDR.T STUK 3/8"

ASS-4009
ASS-4009/T

ASS-5009
ASS-5009/T

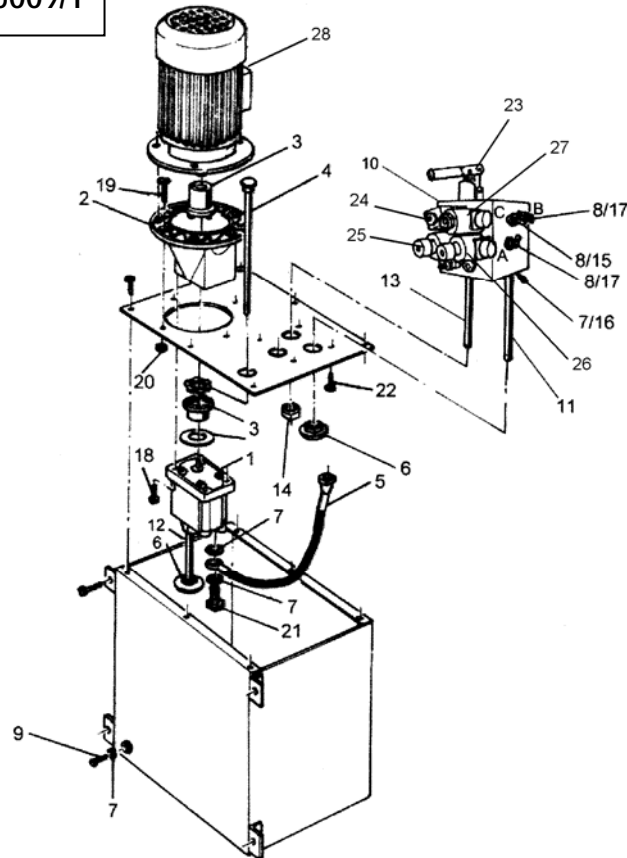

POS	BESTEL NUMMER ORDER NUMBER BESTELLUNGSNUM	DESCRIPTION	BESCHREIBUNG	OMSCHRIJVING
1.	OS40-0193	PUMP AP 100/5		HYDR.POMP
2.	OS40-0239	PUMP SPIDER		FLENS LSE 201 (OLIEPOMP)
3.	OS00-40050	JOINT		MEENEMER (OLIEPOMP)
4.	OS40-0021	OIL DIPSTICK		OLIEPEILSTOK
5.	OS00-40009	HOSE R2 AT 3/8" L=300MM		HYDR.SLANG R2AT 300 x3/8
6.	OS40-0027	FILTER		FILTER 3/8" (OLIEPOMP)
7.	OS40-0020	COPPER WASHER 3/8"		HYDR.KOPEREN-RING 3/8"
8.	OS40-0019	COPPER WASHER 1/4"		HYDR.KOPEREN-RING 1/4"
9.	OS40-0060	DRAINPLUG 3/8"		AFTAPPLUG 3/8"
10.	OS40-0306	CONTROL UNIT		HYDR.VERDEELBLOK
11.	LIGH0114	THREADED HOSE 3/8"		KUNSTSTOF PIJP16MM L500MM
12.	LIGH0114	THREADED HOSE 3/8"		KUNSTSTOF PIJP16MM L500MM
13.	OS40-0305	THREADED HOSE 1/4" 280MM		KUNSTSTOF PIJP 280MM 1/4"
14.	OS40-0342	NON RETURN VALVE		TERUGSLAGVENTIEL
15.	15014014	NIPLES M/M 1/4"		HYDR.ADAPTOR 1/4-1/4 M-M
16.	OS40-0013	NIPLES MM 3/8"		HYDR.INSTEELKNIPPEL 3/8"
17.	15014038	NIPLES M/M 1/4"-3/8"		HYDR.ADAPTOR 1/4-3/8 M-M
18.	FSD912M6x30	SOCKET HEAD SCREW		INBUSBOUT
19.	FSD912M10x20	SOCKET HEAD SCREW		INBUSBOUT
20.	FND982M10	NUT		MOER
21.	OS40-0006	HOLED BOLT 3/8"		HYDR.BANJOBOUT 3/8"
22.	FSD912M8x16	SOCKET HEAD SCREW		INBUSBOUT
23.	OS40-0334	MANUAL PUMP		HANDPOMP
24.	OS40-0380	PRESSURE RELIEF VALVE		DRUKONTLAST VENTIEL
25.	OS40-0377	LOWERING SOLENOID VALVE		DAALVENTIEL
26.	OS40-0377	PRESSURE VALVE		DAALVENTIEL
27.	OS40-0378	LEVELING SYSTEM SOLENOID VALVE		SYNCHRONISATIEVENTIEL
28.	OS60-0096	ELECTRIC MOTOR		ELECTROMOTOR 3 KW

ASS-4009/WF
ASS-4009/T/WF

ASS-5009/WF
ASS-5009/T/WF

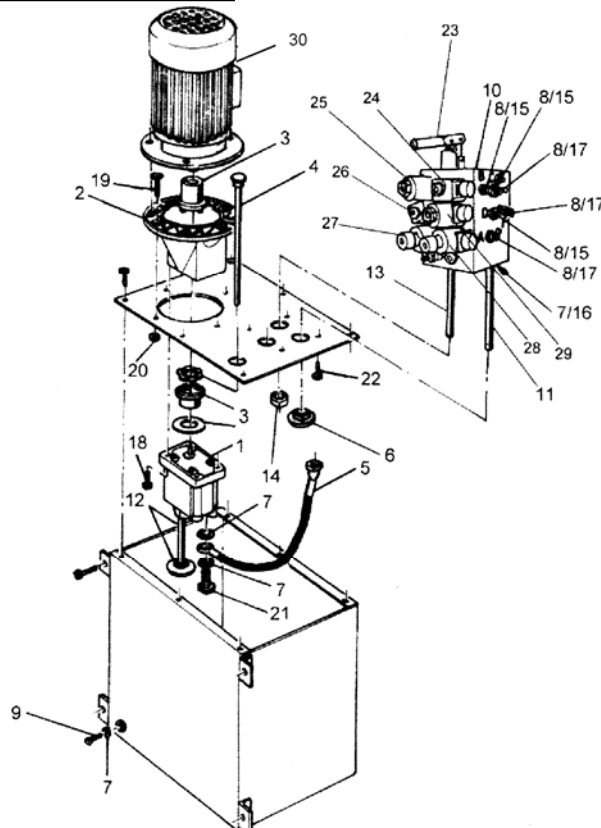

POS	BESTEL NUMMER ORDER NUMBER BESTELLUNGSNUM	DESCRIPTION	BESCHREIBUNG	OMSCHRIJVING
1.	OS40-0193	PUMP AP 100/5		HYDR.POMP
2.	OS40-0239	PUMP SPIDER		FLENS LSE 201201 (OLIEPOMP)
3.	OS00-40050	JOINT		MEENEMER (OLIEPOMP)
4.	OS40-0021	OIL DIPSTICK		OLIEPEILSTOK
5.	OS00-40009	HOSE R2 AT 3/8" L=300MM		HYDR.SLANG R2AT 300 x3/8
6.	OS40-0027	FILTER		FILTER 3/8" (OLIEPOMP)
7.	OS40-0020	COPPER WASHER 3/8"		HYDR.KOPEREN-RING 3/8"
8.	OS40-0019	COPPER WASHER 1/4"		HYDR.KOPEREN-RING 1/4"
9.	OS40-0060	DRAINPLUG 3/8"		AFTAPPLUG 3/8"
10.	OS40-0307	CONTROL UNIT		HYDR.VERDEELBLOK
11.	LIGH0114	THREADED HOSE 3/8"		KUNSTSTOF PIJP16MM L500MM
12.	LIGH0114	THREADED HOSE 3/8"		KUNSTSTOF PIJP16MM L500MM
13.	OS40-0305	THREADED HOSE 1/4" 280MM		KUNSTSTOF PIJP 280MM 1/4"
14.	OS40-0342	NON RETURN VALVE		TERUGSLAGVENTIEL
15.	15014014	NIPLES M/M 1/4"		HYDR.ADAPTOR 1/4-1/4 M-M
16.	OS40-0013	NIPLES MM 3/8"		HYDR.INSTEEKNIPPEL 3/8"
17.	15014038	NIPLES M/M 1/4"-3/8"		HYDR.ADAPTOR 1/4-3/8 M-M
18.	FSD912M6x30	SOCKET HEAD SCREW		INBUSBOUT
19.	FSD912M10x20	SOCKET HEAD SCREW		INBUSBOUT
20.	FND985M10	NUT		MOER
21.	OS40-0006	HOLED BOLT 3/8"		HYDR.BANJOBOUT 3/8"
22.	FSD912M8x16	SOCKET HEAD SCREW		INBUSBOUT
23.	OS40-0334	MANUAL PUMP		HANDPOMP
24.	OS40-0382	CHANGE -OVER LIFT TABLE ELECTROVALVE		
25.	OS40-0378	LEVELLING LIFT TABLE ELECTROVALVE		SYNCHRONISATIEVENTIEL
26.	OS40-0378	PRESSURE RELIEF VALVE		SYNCHRONISATIEVENTIEL
27.	OS40-0377	LOWERING ELECTROVALVE MAIN LIFT		DAALVENTIEL
28.	OS40-0377	CHANGE OVER MAIN IFT/ LIFT TABLE ELECTRO VALVE		DAALVENTIEL
29.	OS40-0378	LEVELLING SYSTEM ELECTRO VALVE		SYNCHRONISATIEVENTIEL
30.	OS60-0096	ELECTRIC MOTOR		ELECTROMOTOR 3 KW

ASS-4009
ASS-5009

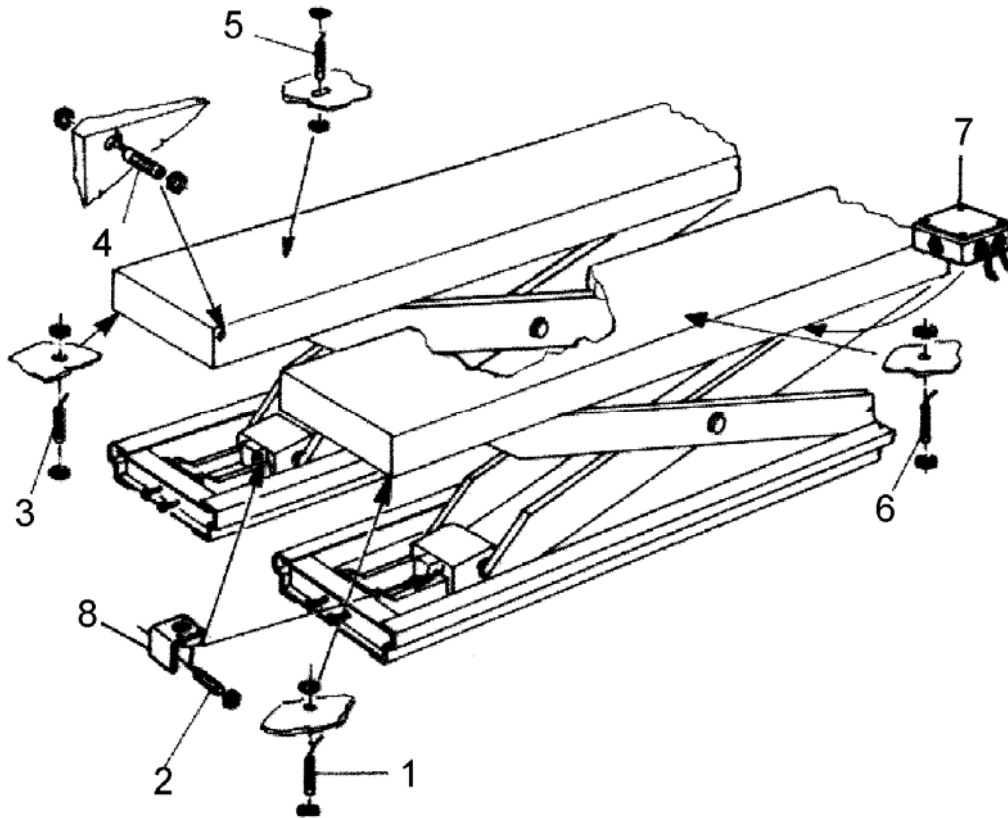

POS	BESTEL NUMMER ORDER NUMBER BESTELLUNGSNUM	DESCRIPTION	BESCHREIBUNG	OMSCHRIJVING
1.	OS60-0113	LEVELLINGSYSTEM LS (P2)		SENSOR NO 2m
2.	OS60-0287	EMCHANICAL SAFETY LS (LM)		SENSOR NC 8m
3.	OS60-0113	LEVELLING SYSTEM LS (P1)		SENSOR NO 2m
4.	OS60-0070	PHOTOCELL (P1)		FOTOCEL NO (P1)
5.	OS60-0287	SAFETY HEIGHT LS (P1)		SENSOR NC 2m
6.	OS60-0113	MAX HEIGHT LIFT TABLE LS (P1)		SENSOR NO 2m
7.	OS60-0132	ELECTRIC BOX		VERDEELDOOS/ELECTRO
8.	OS10-046	ADJUST.BRACKET SAFETY LS		MONTAGE PLAAT (SENSOR)

ASS-4009
ASS-5009

Electric connections platform 1 (OS61-0017)

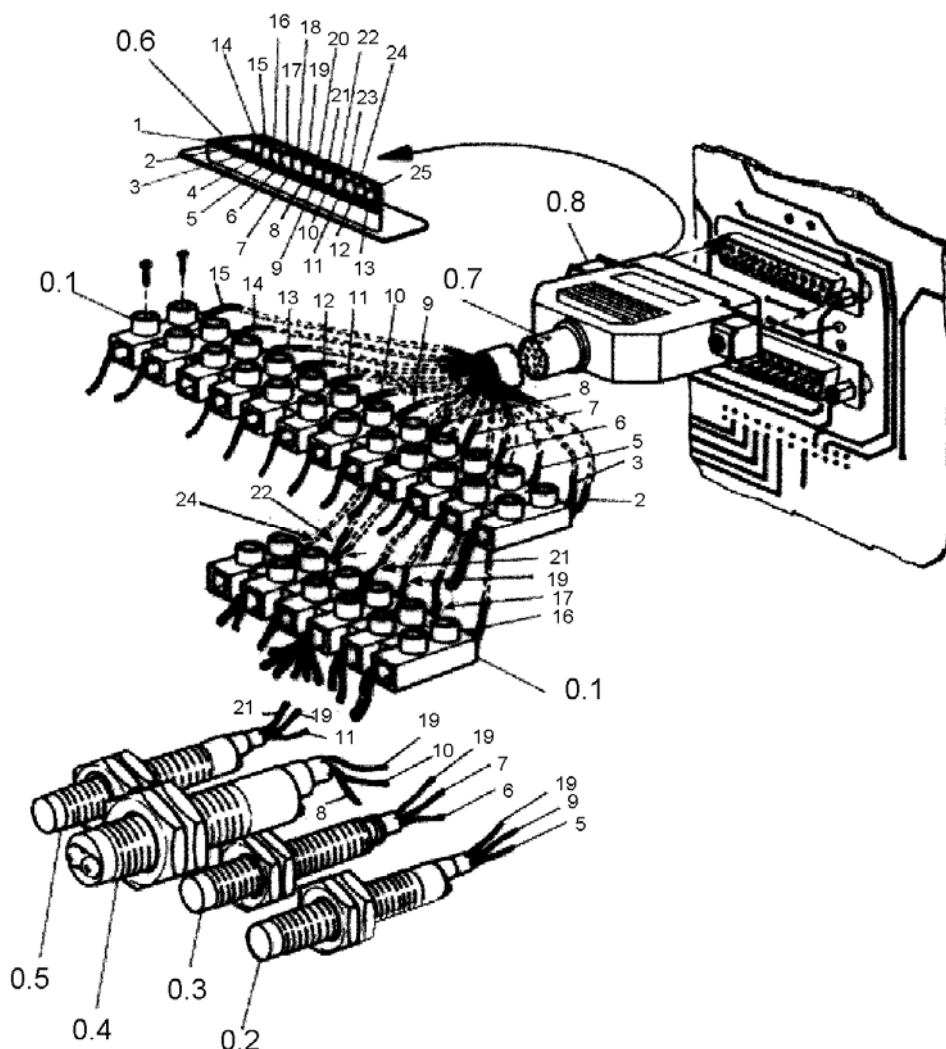

POS	BESTEL NUMMER ORDER NUMBER BESTELLUNGSNUM	DESCRIPTION	BESCHREIBUNG	OMSCHRIJVING
	OS61-0017	CABLE PLATFORM 1 WITH CONNECTOR CP.		ELEK.KABEL P1+CONN
01.	OS60-0325	TERMINAL E 110J		AANSLUITBLOK (E110J)
02.	OS60-0287	SAFETY HEIGHT LS-NC 2M		SENSOR SAFETY HEIGHT P1
03.	OS60-0113	LEVELLING SYSTEM LS-NO 2M		SENCOR SYNCHR.SYST.P1/P2
04.	OS60-0070	PHOTOCELL OCV-81-C-PNP-NO		FOTOCCEL NO (P1)
05.	OS60-0287	MECHANICAL SAFETY LS-NC		SENCOR NC 2M
06.	OS60-0245	MALE CONNECTOR 25P		ADAPTOR/CONTRA (25P)
07.	VMVL12x0,75	CABLE 12x0.50		LICHTKABEL 12 ADERIG
08.	OS60-0246	CONNECTOR SHELL 25P		ADAPTOR/INSTEEL (SHELL 25P)

ASS-4009
ASS-5009

Electric connections platform 2 (OS61-0016)

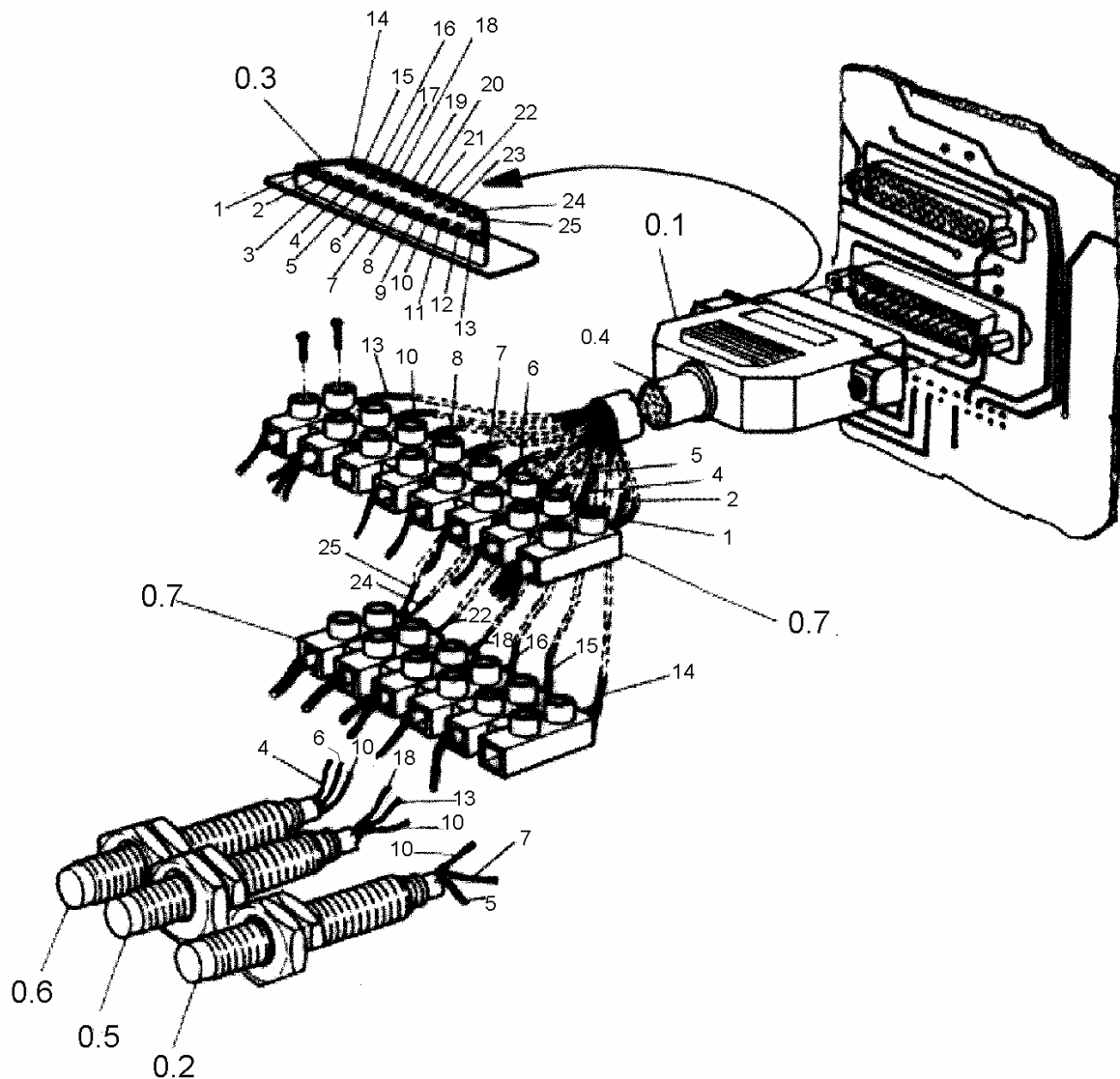

POS	BESTEL NUMMER ORDER NUMBER BESTELLUNGSNUM	DESCRIPTION	BESCHREIBUNG	OMSCHRIJVING
	OS61-0016	CABLE PLATFORM 2 WITH CONNECTOR CPL.		ELEK.KABEL P2+CONN
01.	OS60-0246	CONNECTOR SHELL		ADAPTOR/INSTEK(SHELL 25P)
02.	OS60-0287	SAFETY HEIGHT LS-NC 2M		SENCOR NC 2M
03.	OS60-0244	FEMALE CONNECTOR 25P		ADAPTOR/VROUW (25P)
04.	VMVL12X0,50	CABLE		KABEL 12 ADERIG
05.	OS60-0362	MAX HEIGHT PLATFORM LS-NO 6M		SENCOR NO 6M
06.	OS60-0362	LEVELLING SYSTEM PLATFORM LS-NO 6M		SENCOR NO 6M
07.	OS60-0325	TERMINAL E 110J		AANSLUITBLOK (E110J)

ASS-4009/T
ASS-5009/T

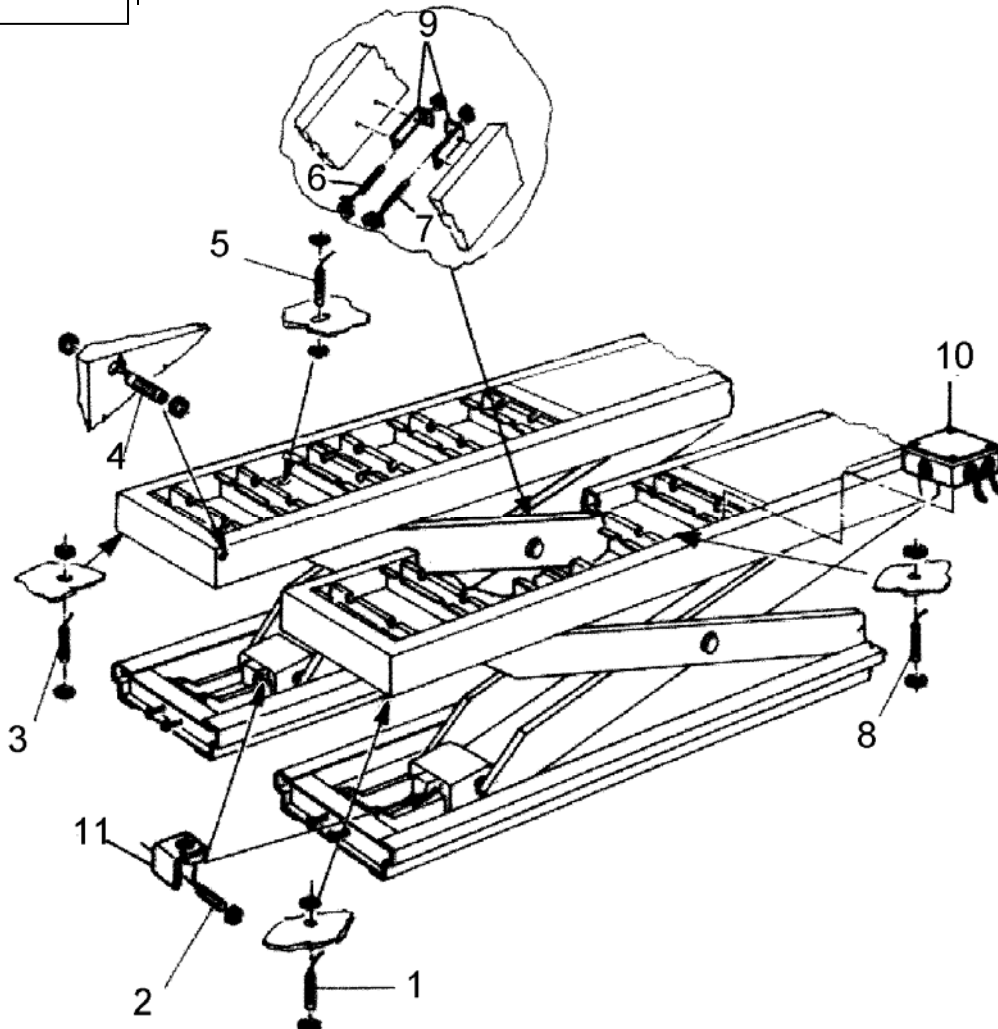

POS	BESTEL NUMMER ORDER NUMBER BESTELLUNGSNUM	DESCRIPTION	BESCHREIBUNG	OMSCHRIJVING
1.	OS60-0113	LEVELLING SYSTEM LS (P2)		SENSOR SYNCH.SYST.P1/P2
2.	OS60-0287	SAFETY HEIGHT LS-NC 2M		SENSOR NC 2M
3.	OS60-0113	LEVELLING SYSTEM LS (P1)		SENSOR SYNCHR.SYST.P1/P2
4.	OS60-0070	PHOTOCELL (P1)		FOTOCCEL (P1)
5.	OS60-0287	SAFETY HEIGHTLS (P1)		SENSOR SAFETY HEIGHT P1
6.	OS60-0113	SENCOR NO 2M		SENCOR 1 LS
7.	OS60-0113	SENCOR NO 2M		SENCOR 1 LS
8.	OS60-0113	SENCOR NO 2M		SENCOR 1 LS
9.	OS10-047	ADJUSTING BRACKET LS		SENSOR HOUDER
10.	OS60-0132	ELECTRIC BOX		VERDEELDOOS/ELECTRO
11.	OS10-046	ADJUSTING BRACKET SAFETY HEIGHT		MONTAGEPLAAT SENSOR

ASS-4009/T
ASS-5009/T

Electric connections platform 1 (OS61-0012)

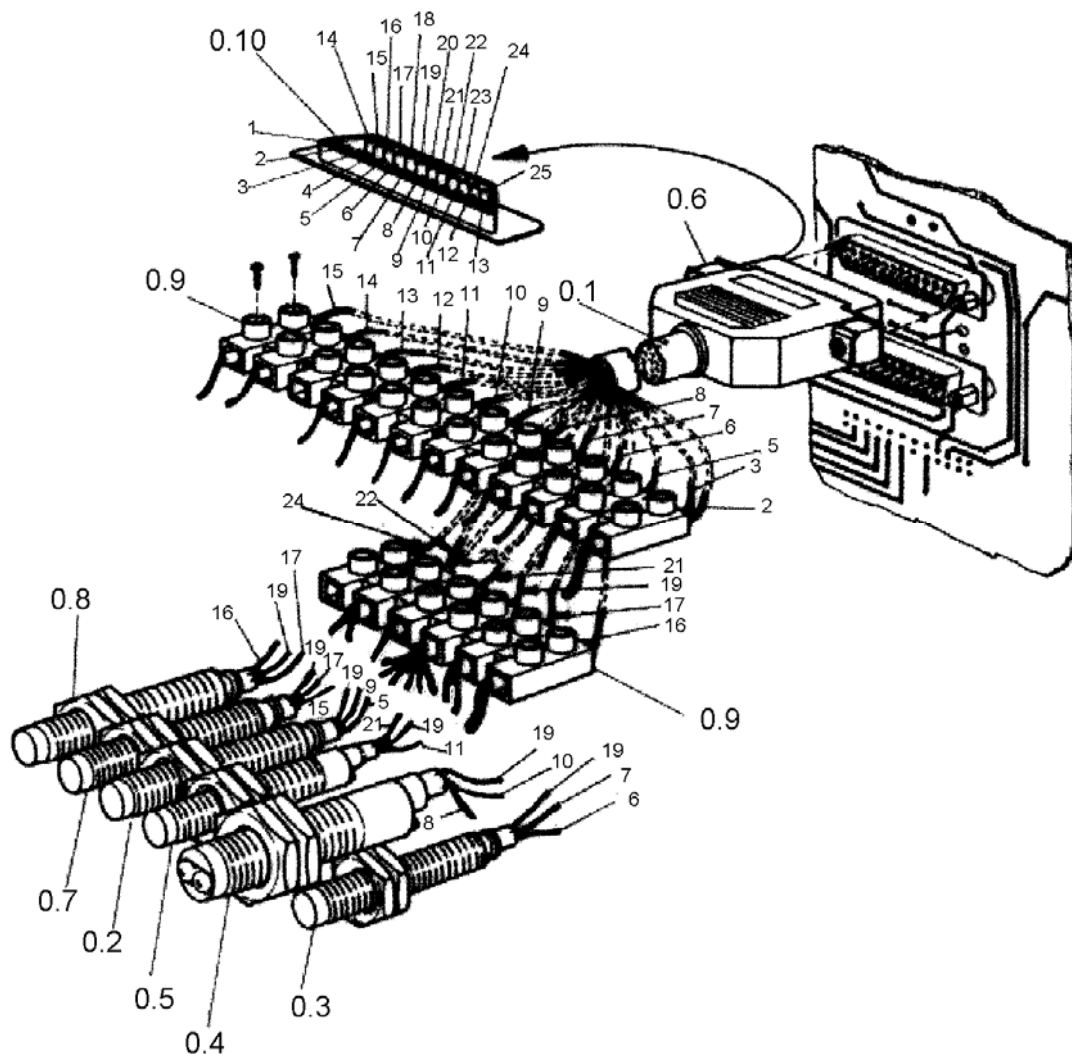

POS	BESTEL NUMMER ORDER NUMBER BESTELLUNGSNUM	DESCRIPTION	BESCHREIBUNG	OMSCHRIJVING
	OS61-0012	CABLE PLATFORM 1 WITH CONNECTOR CPL.		ELEK.KABEL P1+CONN
01	VMVL20X0,50	CABLE 20x0.50		LICHTKABEL 20X0,50
02	OS60-0287	SAFETY HEIGHT RUNWAYS LS-NC 2M		SENSOR SAFETY HEIGHT P1
03	OS60-0113	LEVELLING SYSTEM RUNWAYS LS-NO 2M		SENCOR SYNCHR.SYST.P1/P2
04	OS60-0070	PHOTOCEL OCV-81-C-PNP-NO		FOTOCEL NO (P1)
05	OS60-0287	SAFETY HEIGHTLS (P1)		SENSOR SAFETY HEIGHT P1
06	OS60-0246	CONNECTOR SHELL 25P		ADAPTOR/INSTEEL(SHELL 25P)
07	OS60-0113	SENCOR NO 2M		SENCOR 1 LS
08	OS60-0113	SENCOR NO 2M		SENCOR 1 LS
09	OS60-0325	TERMINAL E 110 J		AANSLUITBLOK (E 110 J)
10	OS60-0245	MALE CONNECTOR 25 P		ADAPTOR/CONTRA (25P)

ASS-4009/T
 ASS-5009/T

Electric connections platform 2 (OS61-0013)

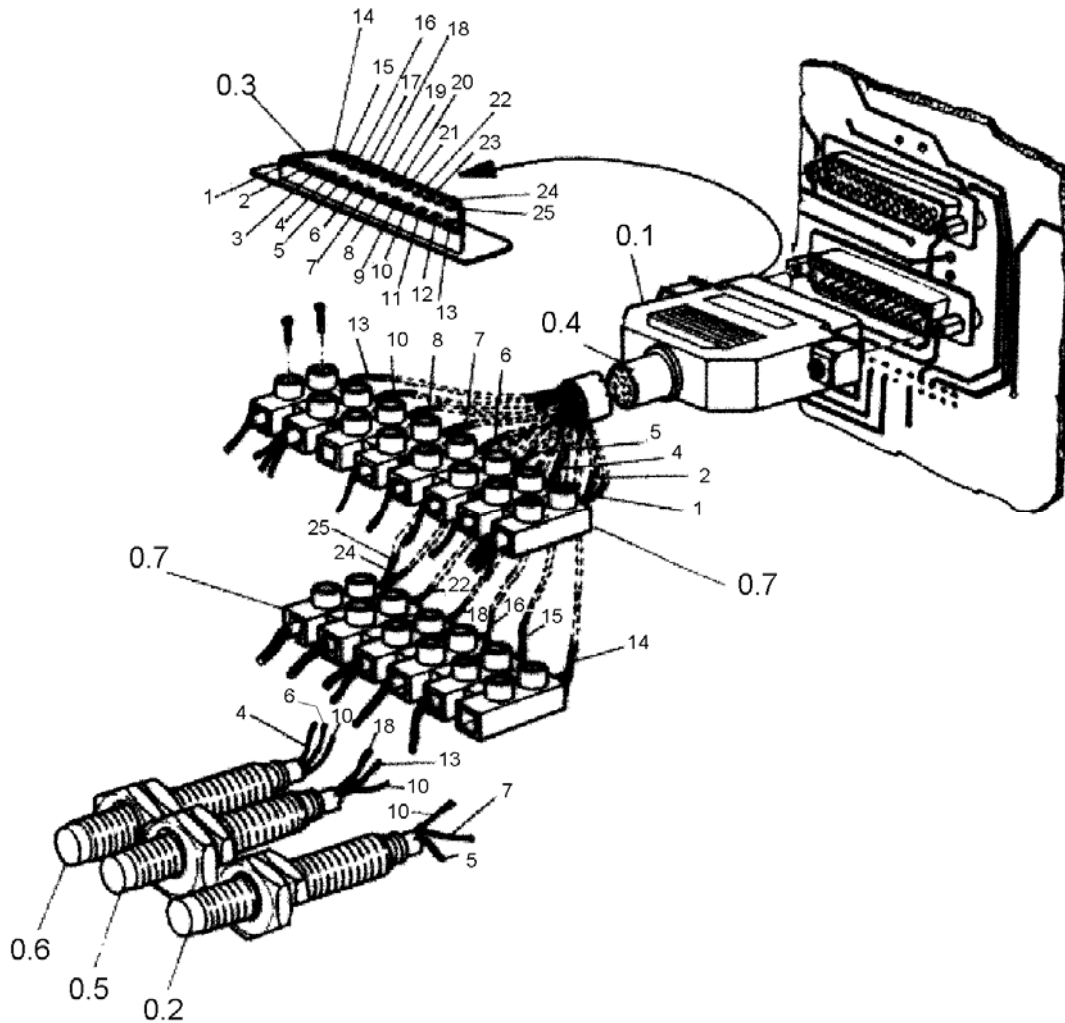

POS	BESTEL NUMMER ORDER NUMBER BESTELLUNGSNUM	DESCRIPTION	BESCHREIBUNG	OMSCHRIJVING
	OS61-0013	CABLE PLATFORM 2 WITH CONNECTOR CPL.		ELEK.KABEL P2+CONN
01	OS60-0244	FEMALE CONNECTOR 25 P		ADAPTOR/VROUW (25P)
02	OS60-0287	MECHANICAL SAFETY LS-NC 8M		SENSOR NC 2M.
03	VMVL20X0,50	CABLE 20x 0.50		CABLE 20x 0.50
04	OS60-0246	CONNECTOR SHELL 25 P		ADAPTOR / INSTEELK (SHELL 25P)
05	OS60-0113	MAX HEIGHT LS RUNWAY LS-NO 2M		SENCOR MAX.HEFHOOGTE P1
06	OS60-0113	LEVELLING SYSTEM RUNWAY LS-NO 2M		SENCOR SYNCHR.SYST.P1/P2
07	OS60-0325	TERMINAL E 110 J		AANSLUITBLOK (E110J)

ASS-4009/WF
ASS-5009/WF

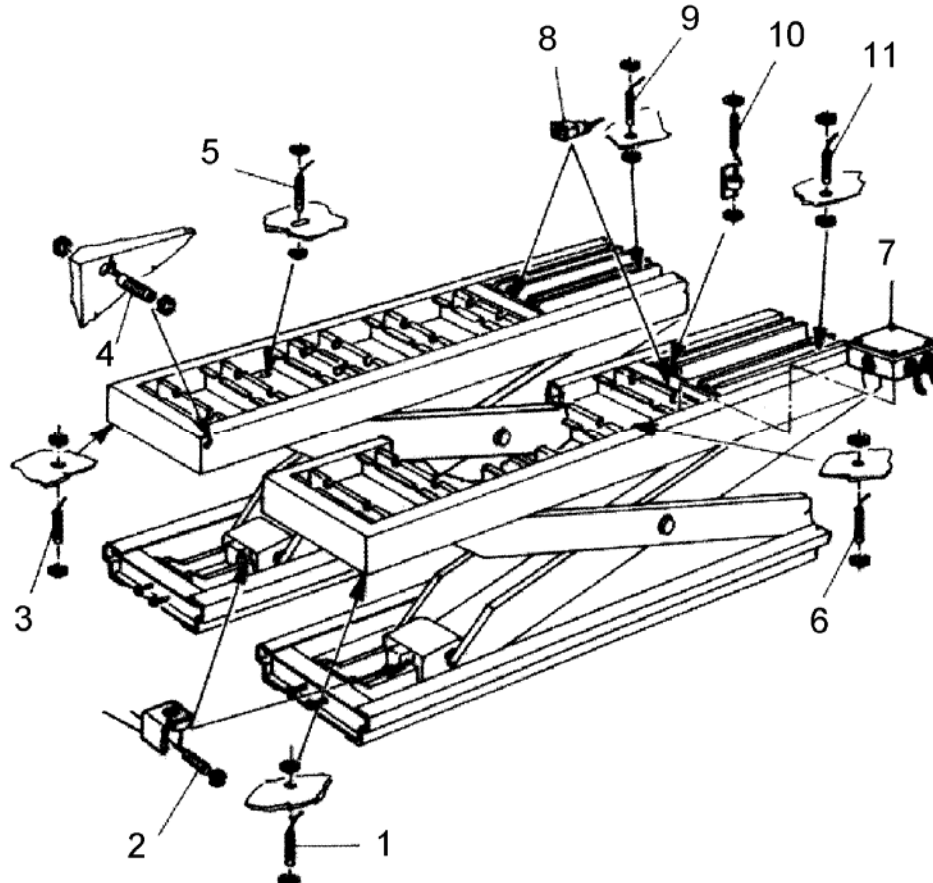

POS	BESTEL NUMMER ORDER NUMBER BESTELLUNGSNUM	DESCRIPTION	BESCHREIBUNG	OMSCHRIJVING
1.	OS60-0113	SENCOR NO 2M		SENCOR NO 2M
2.	OS60-0287	SENSOR NC 2M.		SENSOR NC 2M.
3.	OS60-0113	LEVELLING SYSTEM LS (P1)		SENCOR SYNCHR.SYST.P1/P2
4.	OS60-0070	PHOTOCELL (P1)		FOTOCCEL (P1)
5.	OS60-0287	SENSOR NC 2M.		SENSOR NC 2M.
6.	OS60-0113	SENCOR NO 2M		SENCOR NO 2M
7.	OS60-0132	ELECTRIC BOX		KABELDOOS 100X100X50MM(LEEG)
8.	OS61-0011	CAP CONNECTOR		AFDEKKAP CONNECTOR
9.	OS60-0113	SENCOR NO 2M		SENCOR NO 2M
10.	OS60-0113	SENCOR NO 2M		SENCOR NO 2M
11.	OS60-0113	SENCOR NO 2M		SENCOR NO 2M
12.	OS10-046	ADJUST BRACKET SAFETY LS		MONTAGE PLAAT (SENSOR)
13.	OS10-047	ADJUSTING BRACKET SAFETY LS		SENSOR HOUDER

ASS-4009/WF
ASS-5009/WF

Electric connections platform 1 (OS61-0012)

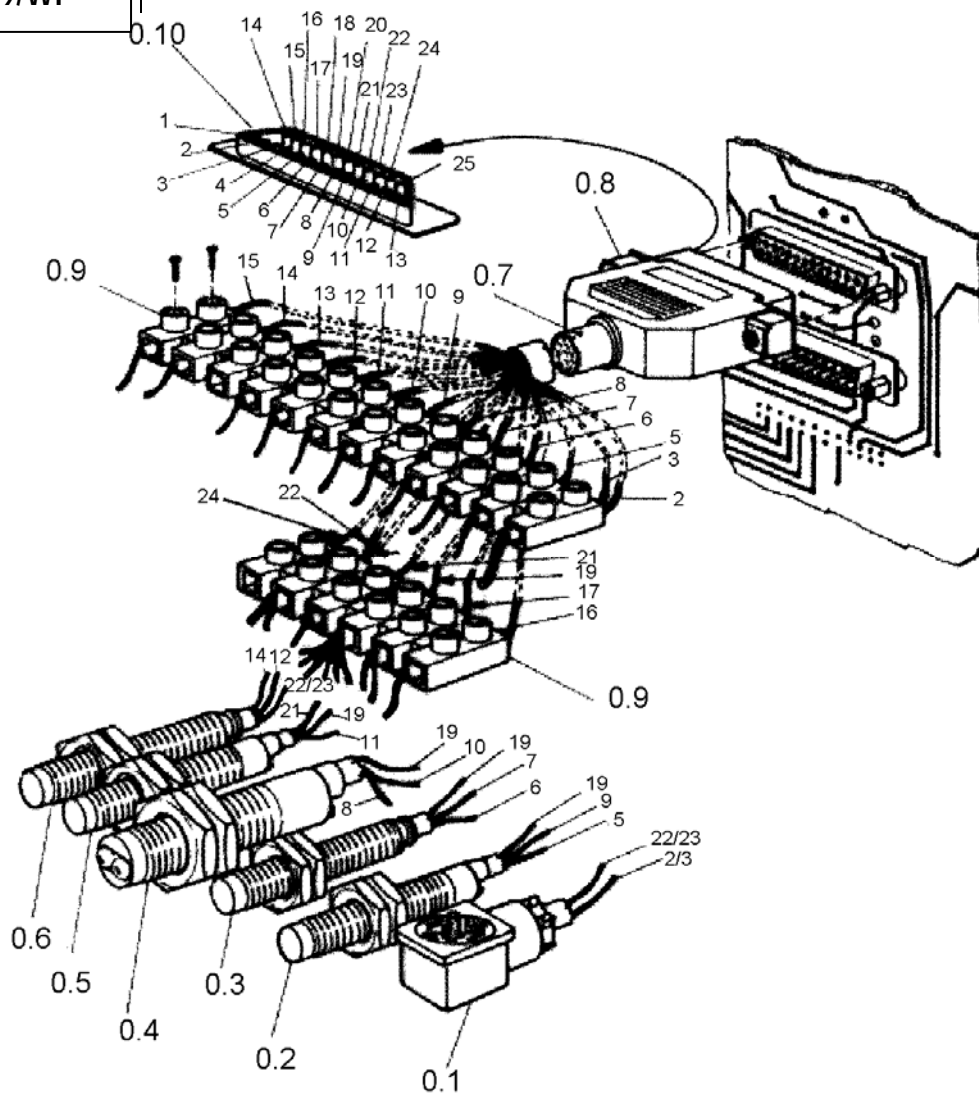

POS	BESTEL NUMMER ORDER NUMBER BESTELLUNGSNUM	DESCRIPTION	BESCHREIBUNG	OMSCHRIJVING
	OS61-0012	CABLE PLATFORM 1 WITH CONNECTOR		ELEK.KABEL P1+CONN
01	OS61-0011	CONNECTOR CAP		AFDEKKAP CONNECTOR
02	OS60-0287	SAFETY HEIGHT RUNWAYS LS-NC 2M		SENSOR SAFETY HEIGHT P1
03	OS60-0113	LEVELLING SYSTEM RUNWAYS LS-NO 2M		SENCOR SYNCHR.SYST.P1/P2
04	OS60-0070	PHOTOCEL OCV-81-C-PNP-NO		FOTOCCEL NO (P1)
05	OS60-0287	SENSOR NC 2M.		SENSOR NC 2M.
06	OS60-0113	SENCOR NO 2M		SENCOR NO 2M
07	VMVL20X0,50	CABLE 20x 0.50		CABLE 20x 0.50
08	OS60-0246	CONNECTOR SHELL 25P		ADAPTOR/INSTEEL (SHELL 25P)
09	OS60-0325	TERMINAL E 110J		AANSLUITBLOK (E110J)
10	OS60-0245	MALE CONNECTOR		ADAPTOR/CONTRA (25P)

ASS-4009/WF
ASS-5009/WF

Electric connections platform 2 (OS61-0013)

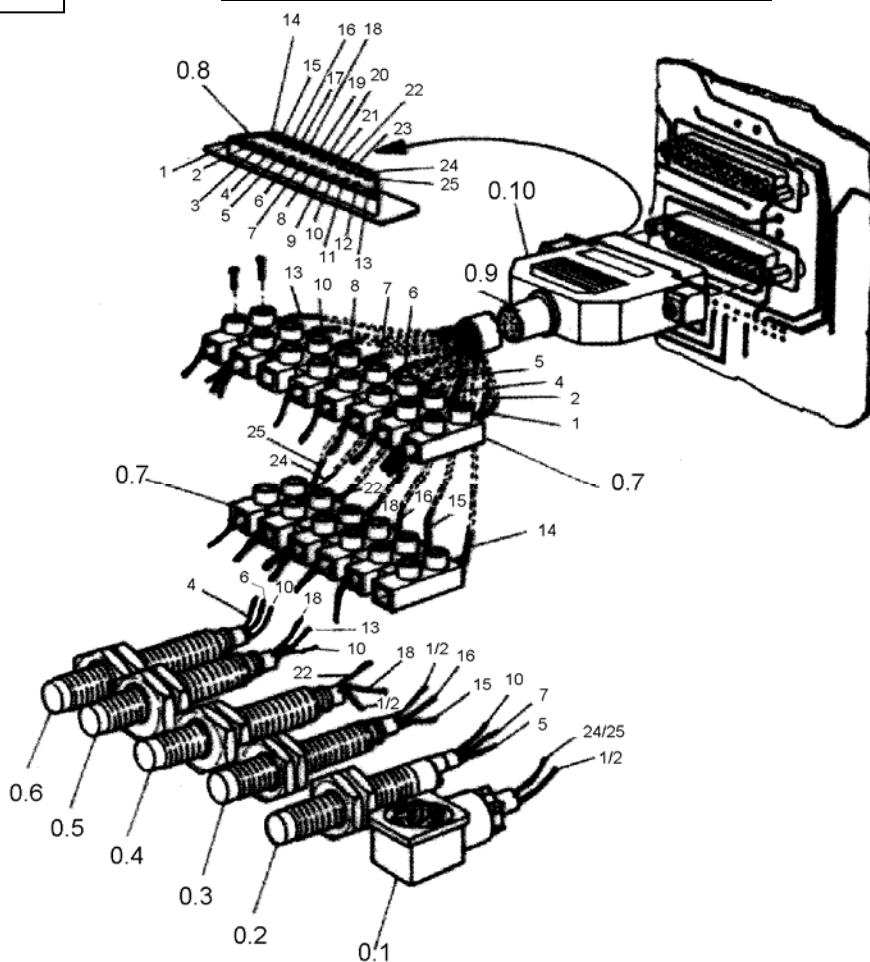

POS	BESTEL NUMMER ORDER NUMBER BESTELLUNGSNUM	DESCRIPTION	BESCHREIBUNG	OMSCHRIJVING
	OS61-0013	CABLE PLATFORM 2 WITH CONNECTOR CPL		ELEK.KABEL P2+CONN
01	OS61-0011	CONNECTOR CAP		AFDEKKAP CONNECTOR
02	OS60-0287	SAFETY HEIGHT RUNWAYS LS-NC 2M		SENSOR SAFETY HEIGHT P1
03	OS60-0113	SENCOR NO 2M		SENCOR NO 2M
04	OS60-0113	SENCOR NO 2M		SENCOR NO 2M
05	OS60-0113	SENCOR NO 2M		SENCOR NO 2M
06	OS60-0113	SENCOR NO 2M		SENCOR NO 2M
07	OS60-0325	TERMINAL E 110 J		AANSLUITBLOK (E 110 J)
08	OS60-0244	FEMALE CONNECTOR 25P		ADAPTOR / VROUW (25P)
09	VMVL20X0,50	CABLE 20x 0.50		CABLE 20x 0.50
10	OS60-0246	CONNECTOR SHELL 25P		ADAPTOR/INSTEK (SHELL 25P)

ASS-4009/T/WF
ASS-5009/T/WF

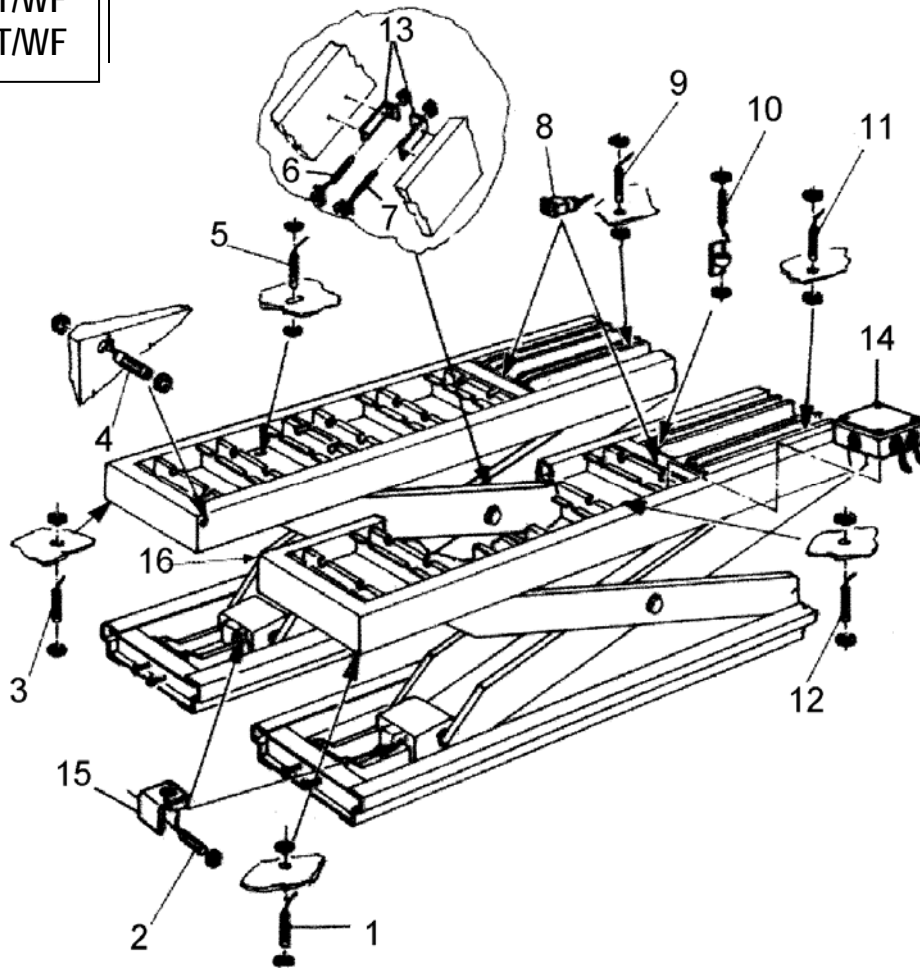

POS	BESTEL NUMMER ORDER NUMBER BESTELLUNGSNUM	DESCRIPTION	BESCHREIBUNG	OMSCHRIJVING
1.	OS60-0113	SENCOR NO 2M		SENCOR NO 2M
2.	OS60-0287	SAFETY HEIGHT RUNWAYS LS-NC 2M		SENSOR SAFETY HEIGHT P1
3.	OS60-0113-	SENCOR NO 2M		SENCOR NO 2M
4.	OS60-0070	PHOTOCELL (P1)		FOTOCCEL (P1)
5.	OS60-0287	SAFETY HEIGHT RUNWAYS LS-NC 2M		SENSOR SAFETY HEIGHT P1
6.	OS60-0362-1P	1°POSITION LS (P1)		EINDSCHAKELAAR 6MT/NO
7.	OS60-0362-2P	2°POSITION LS (P1)		EINDSCHAKELAAR 6MT/NO
8.	OS61-0011	CAP CONNECTOR		AFDEKKAP CONNECTOR
9.	OS60-0113	SENCOR NO 2M		SENCOR NO 2M
10.	OS60-0113	SENCOR NO 2M		SENCOR NO 2M
11.	OS60-0113	SENCOR NO 2M		SENCOR NO 2M
12.	OS60-0113	SENCOR NO 2M		SENCOR NO 2M
13.	OS10-047	ADJUSTING BRACKET LS		SENCOR HOUDER
14.	OS60-0132	ELECTRIC BOX		VERDEELDOOS/ELECTRO
15.	OS10-046	ADJUST BRACKET SAFETY LS		MONTAGE PLAAT (SENSOR)
16.	OS60-0026	REFLECTOR		REFLECTOR (TBV FOTOCCEL)

ASS-4009/T/WF
ASS-5009/T/WF

Electric connections platform 1 (OS61-0012)

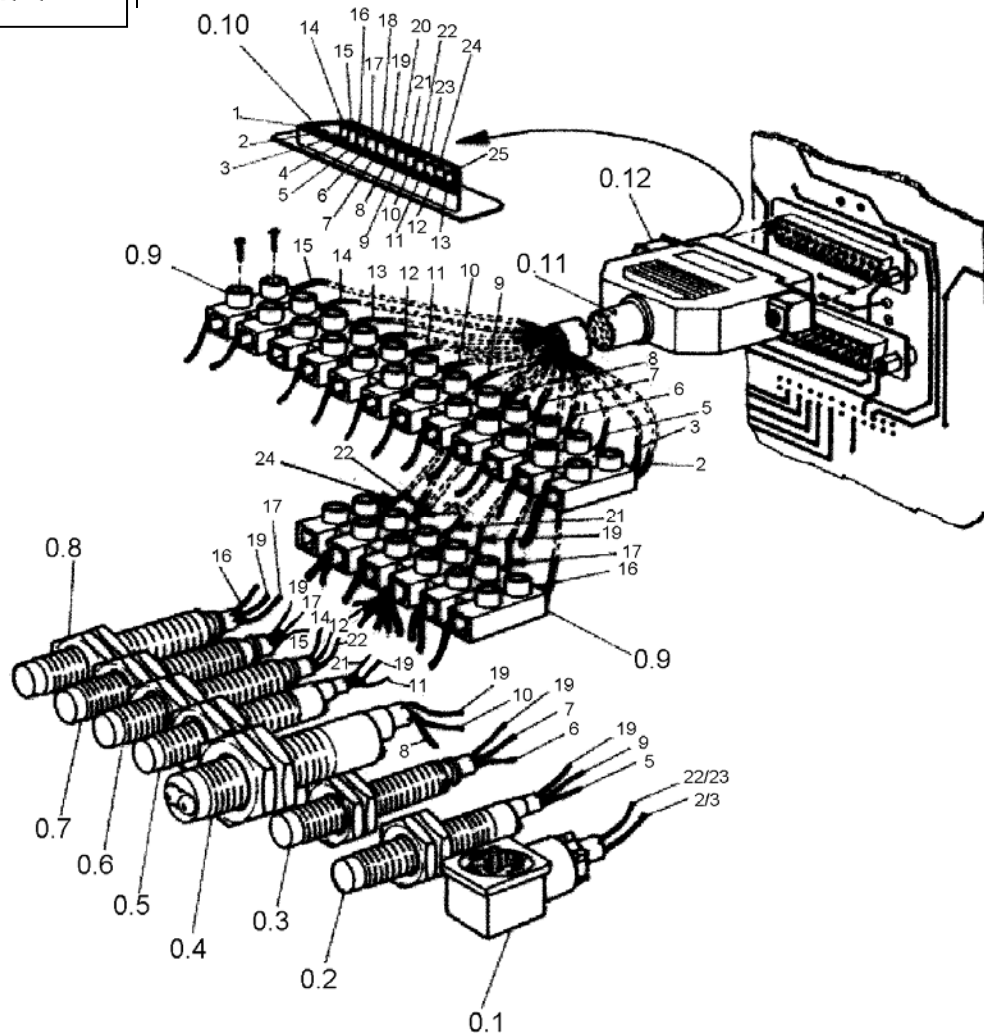

POS	BESTEL NUMMER ORDER NUMBER BESTELLUNGSNUM	DESCRIPTION	BESCHREIBUNG	OMSCHRIJVING
	OS61-0012	CABLE PLATFORM 1 WITH CONNECTOR cpl.		ELEK.KABEL P1+CONN
01	OS61-0011	CONNECTOR CAP		AFDEKKAP CONNECTOR
02	OS60-0287	SAFETY HEIGHT RUNWAYS LS-NC 2M		SENSOR SAFETY HEIGHT P1
03	OS60-0113	SENCOR NO 2M		SENCOR NO 2M
04	OS60-0070	PHOTOCEL OCV-81-C-PNP-NO		FOTOCEL NO (P1)
05	OS60-0287	SAFETY HEIGHT RUNWAYS LS-NC 2M		SENSOR SAFETY HEIGHT P1
06	OS60-0113	SENCOR NO 2M		SENCOR NO 2M
07	OS60-0113	SENCOR NO 2M		SENCOR NO 2M
08	OS60-0113	SENCOR NO 2M		SENCOR NO 2M
09	OS60-0325	TERMINAL E 110J		AANSLUITBLOK (E110J)
10	OS60-0245	MALE CONNECTOR 25P		ADAPTOR/CONTRA (25P)
11	VMVL20X0,50	CABLE 20x 0.50		CABLE 20x 0.50
12	OS60-0246	CONNECTOR SHELL		ADAPTOR/INSTEEL(SHELL 25P)

ASS-4009/T/WF
ASS-5009/T/WF

Electric connections platform 2 (OS61-0013)

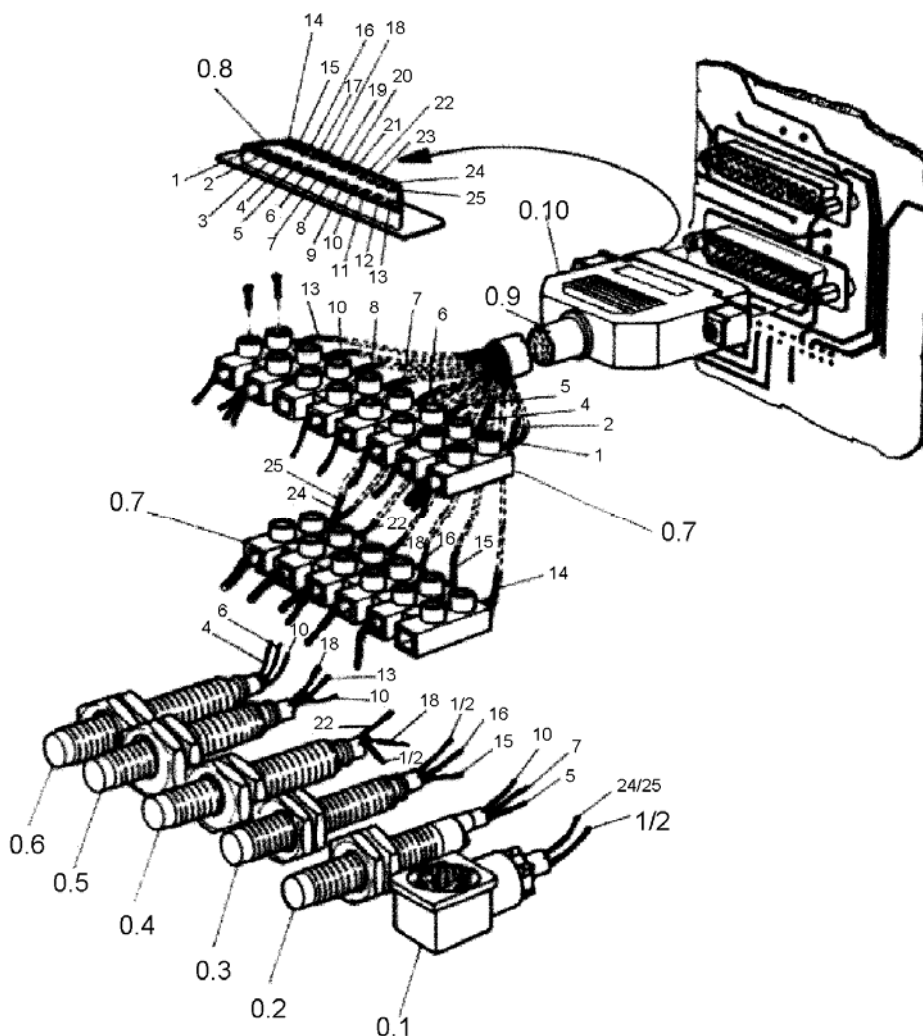

POS	BESTEL NUMMER ORDER NUMBER BESTELLUNGSNUM	DESCRIPTION	BESCHREIBUNG	OMSCHRIJVING
	OS61-0013	SENCOR NO 2M		SENCOR NO 2M
1.	OS61-0011	CONNECTOR CAP		AFDEKKAP CONNECTOR
2.	OS60-0287	SAFETY HEIGHT RUNWAYS LS-NC 2M		SENSOR SAFETY HEIGHT P1
3.	OS60-0113	SENCOR NO 2M		SENCOR NO 2M
4.	OS60-0113-	SENCOR NO 2M		SENCOR NO 2M
5.	OS60-0113	SENCOR NO 2M		SENCOR NO 2M
6.	OS60-0113	SENCOR NO 2M		SENCOR NO 2M
7.	OS60-0325	TERMINAL E 110 J		AANSLUITBLOK (E 110 J)
8.	OS60-0244	FEMALE CONNECTOR 25P		ADAPTOR / VROUW (25P)
9.	VMVL20X0.50	CABLE 20x 0.50		CABLE 20x 0.50
10.	OS60-0246	CONNECTOR SHELL 25P		ADAPTOR/INSTEK (SHELL 25P)

ASS-4009	ASS-5009/WF
ASS-4009	ASS-5009/WF

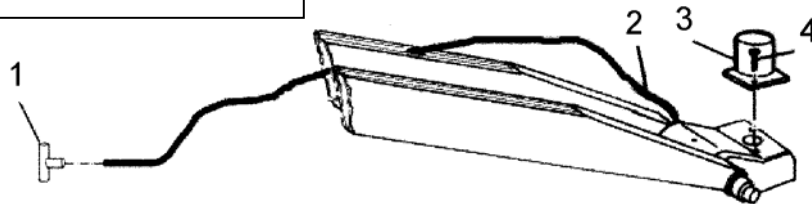

POS	BESTEL NUMBER ORDER NUMBER BESTELLUNGSNUM	DESCRIPTION	BESCHREIBUNG	OMSCHRIJVING
1.	OS50-0005	*T*CONNECTION 6x4		PNEUM.T STUK 6x4MM
2.	TILS6x4/1000	WHITE AIR HOSE		LUCHTSLANG (WIT)
3.	OS50-042	AIR CILINDER		PNEUM.VERGRENDELKLEP CPL.
4.	FSD912M6x40	SCREW		INBUSBOUT

ASS-4009/T	ASS-5009/T
ASS-4009/T/WF	ASS-5009/T/WF

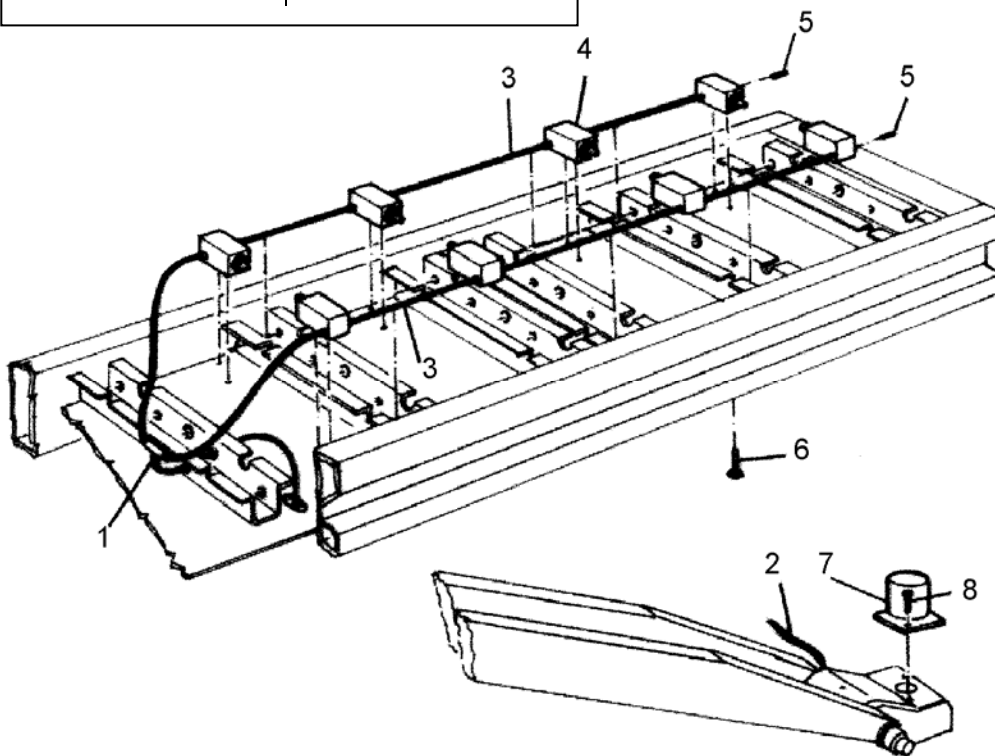

POS	BESTEL NUMBER ORDER NUMBER BESTELLUNGSNUM	DESCRIPTION	BESCHREIBUNG	OMSCHRIJVING
1.	OS50-0005	*T*CONNECTION 6x4		PNEUM.T STUK 6x4MM
2.	TILS6x4/1000	WHITE AIR HOSE		LUCHTSLANG (WIT)
3.	TILS6x4/1000	BLUE AIR HOSE 6x4		LUCHTSLANG (BLAUW)
4.	OS50-0045	AIR CILINDER		LUCHTCILINDER KOMP.PL.
5.	OS50-0048	CONIC PLUG 1/8"		PNEUM.INSTEEKNIPPEL 6/4"
6.	FSD912M6x10	SCREW		INBUSBOUT
7.	OS50-042	AIR CILINDER		PNEUM.VERGRENDELKLEP CPL.
8.	FSD912M6x40	SCREW		INBUSBOUT

ASS-4009
ASS-4009/T
ASS-4009/WF
ASS-4009/T/WF

ASS-5009
ASS-5009/T
ASS-5009/WF
ASS-5009/T/WF

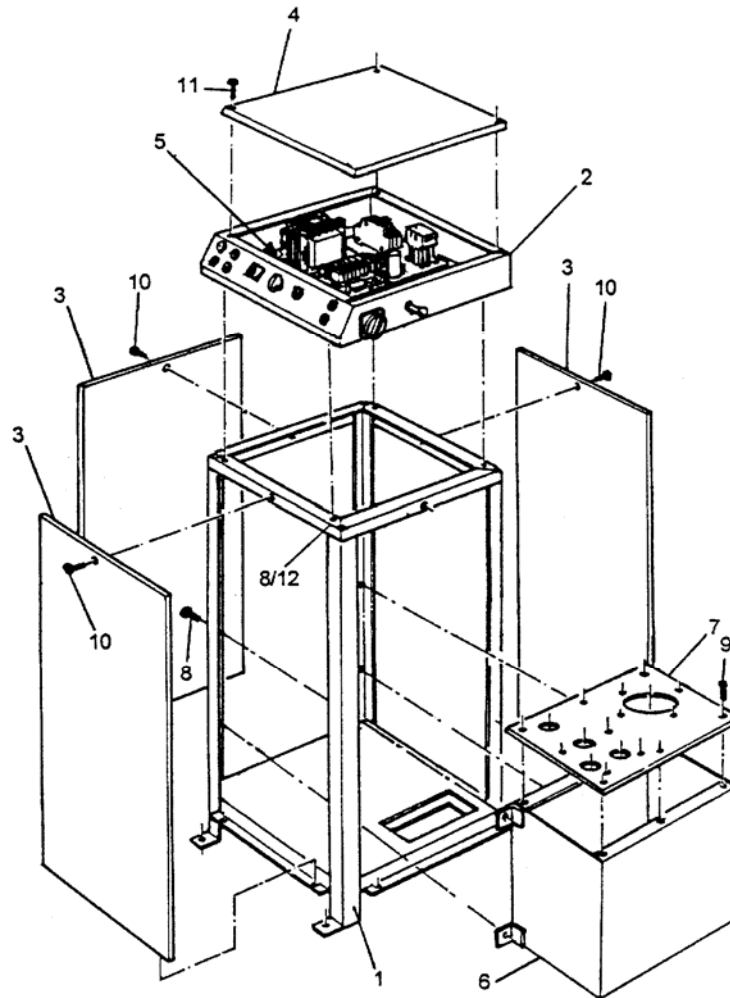

POS	BESTEL NUMMER ORDER NUMBER BESTELLUNGSNUM	DESCRIPTION	BESCHREIBUNG	OMSCHRIJVING
1.	OS10-200	POWER UNIT FRAME		RAAMWERK BED.KAST
2.	OS10-209	POWER UNIT TOP		FRAME KOP.BED.KAST
3.	OS10-202	SIDE PANEL		ZIJPANEEL BED.KAST
4.	OS10-203	TOP COVER		AFDEKPLAAT (BED.KAST)
5.	OS10-173	PLATE CONTROL DESK		MONTAGEPLAAT (BED.KAST)
6.	OS10-254	OIL TANK		OLIE RESERVOIR (KAAL)
7.	OS10-261	TANK COVER		DEKSEL (OLIE RESERVOIR)
8.	FSD912M6x20	SOCKET HEAD SCREW		INBUSBOUT
9.	FS7380M6x16	SOCKET HEAD SCREW		INBUSBOUT
10.	FS7380M6x30	SOCKET HEAD SCREW		INBUSBOUT
11.	FS7380M6x30	SOCKET HEAD SCREW		INBUSBOUT
12.	FND934M6	NUT		MOER

ASS-4009/T	ASS-5009/T
ASS-4009/T/WF	ASS-5009/T/WF

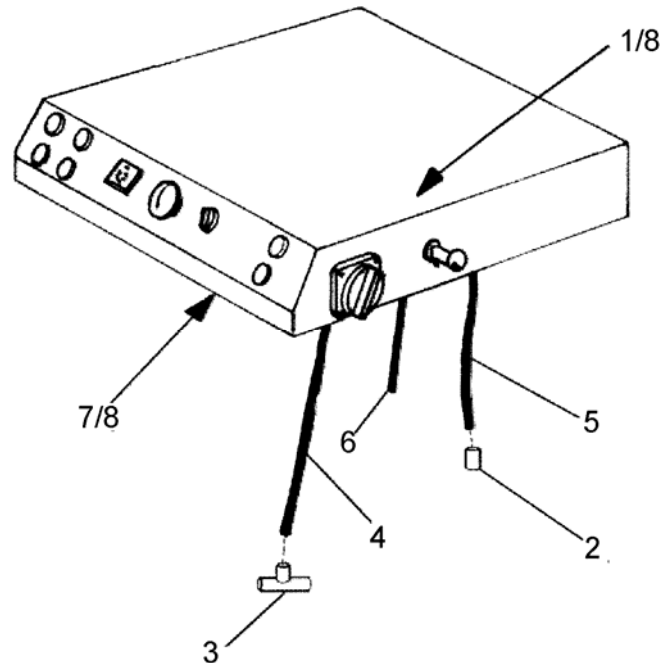

POS	BESTEL NUMMER ORDER NUMBER BESTELLUNGSNUM	DESCRIPTION	BESCHREIBUNG	OMSCHRIJVING
1.	OS40-0204	5 SLIP PLATE VALVE		KOMP.PLAAT VENTIEL
2.	OS50-0034	CONNECTION		LUCHTVENTIEL DC
3.	OS50-0005	"T" CONNECTION		PNEUM.T STUK 6X4MM
4.	TILS6x4/1000	AIR HOSE		LUCHTSLANG 6X4MM/P.M1
5.	TILS6x4/1000	AIR HOSE		LUCHTSLANG 6X4MM/P.M1
6.	TILS6x4/1000	AIR HOSE		LUCHTSLANG 6X4MM/P.M1

ASS-4009	ASS-5009
ASS-4009/T	ASS-5009/T
ASS-4009/WF	ASS-5009/WF
ASS-4009/T/WF	ASS-5009/T/WF

POS	BESTEL NUMMER ORDER NUMBER BESTELLUNGSNUM	DESCRIPTION	BESCHREIBUNG	OMSCHRIJVING
7.	OS50-0002	AIR SOLENOID VALVE 24V AC		PNEUM.SOLENOID VENTIEL
8.	OS50-0027	90°CONNECTION		PNEUM.L STUK ¼"

ASS-4009
ASS-4009/T

ASS-5009
ASS-5009/T

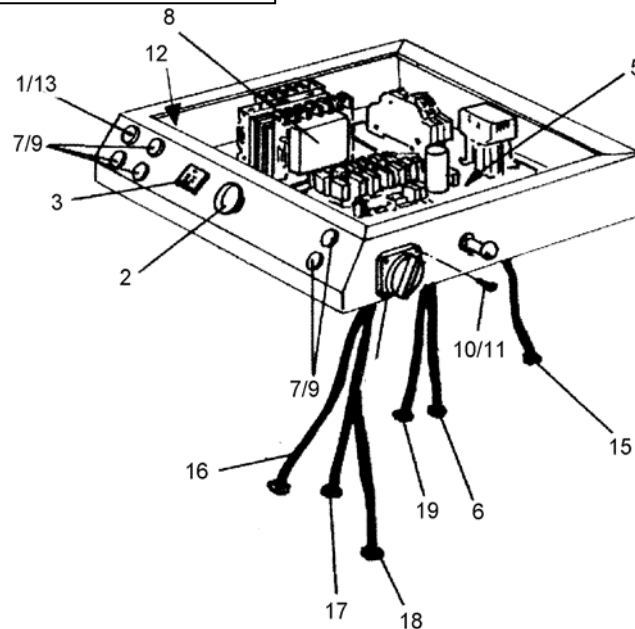

POS	BESTEL NUMMER ORDER NUMBER BESTELLUNGSNUM	DESCRIPTION	BESCHREIBUNG	OMSCHRIJVING
1.	OS60-0265	GREEN PILOT LAMP		CONROLE LAMP (GROEN)
2.	OS60-0116	EMERGENCY PUSH BUTTON		NOOD STOP KNOP
3.	OS60-0098	BEEPER		DAALZOEEMER 24V (GELIJKSTROOM)
4.	OS60-0069	FINISHING		BUITENWERK HOOFDSCHAKELAAR
6.	OS61-0010	AIR ELECTRIC KABEL		ELEK.KABEL AIR
7.	OS60-0114	NEUTRAL PUSH BUTTON		KONTAKTBLOK NO (DRUKKNOP)
8.	OS60-0141	TRNSFORMER		TRANSFORMATOR 100VA
9.	OS60-0243	BUTTON WITH ARROW		PIJL (TBV DRUKKNOP OS60-0114)
10.	FSD7985M4X20	SOCKET HEAD SCREW		METAALSCHROEF M4X20
11.	FND934M4	NUT		MOER
13.	OS60-0093	LAMP 30V 2W		LAMP 30V 2W (BAJONET)
14.	OS61-0001	DISCONNECTOR WITH CABLE		AANSLUIOTKABEL +CONN
15.	OS61-0007	DISCHARGED ELECTRIC CABLE		ELEK.KABEL ZAKVENTIEL 2
16.	OS61-0003	MOTOR CABLE FULGOR		ELEK.KABEL MOTOR/MAGN.SCH
17.	OS61-0004	LEVELLING SYSTEM ELECTRIC CABLE		ELEK.KABEL SYNCH.SENSOR P1
18.	OS61-0005	PRESSURE ELECTRIC CABLE		ELEK.KABEL SYNCH.SENSOR P2
19.	OS61-0006	ADJ.LOWERING ELECTRIC CABLE		ELEK.KABEL ZAKVENTIEL1

ASS-4009

ASS-5009

POS	BESTEL NUMMER ORDER NUMBER BESTELLUNGSNUM	DESCRIPTION	BESCHREIBUNG	OMSCHRIJVING
5.	OS61-0038	PRINTCIRCUITBOARD T06		PRINTCIRCUITBOARD T06 (ASS4009/5009)
12.	OS61-0018	BUTTON CABLE		ELEK.KABEL BUTTON ASS

ASS-4009/T

ASS-5009/T

POS	BESTEL NUMMER ORDER NUMBER BESTELLUNGSNUM	DESCRIPTION	BESCHREIBUNG	OMSCHRIJVING
5.	OS61-0034	PRINTCIRCUITBOARD T06		PRINTCIRCUITBOARD T06 (ASS4009/5009)
12.	OS61-0002	BUTTON CABLE		ELEK.KABEL BUTTON ASS/ WF

ASS-4009/WF
ASS-4009/T/WF

ASS-5009/WF
ASS-5009/T/WF

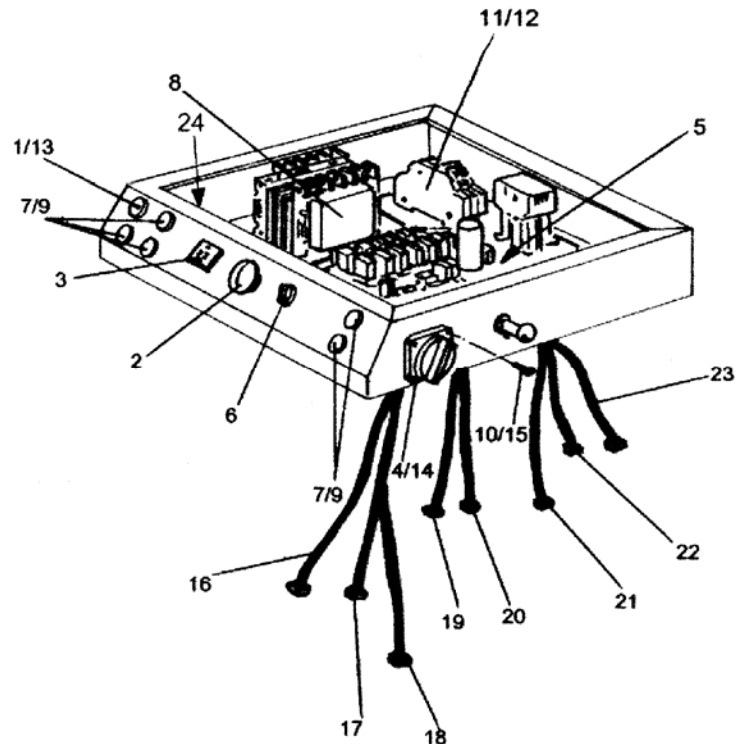

POS	BESTEL NUMMER ORDER NUMBER BESTELLUNGSNUM	DESCRIPTION	BESCHREIBUNG	OMSCHRIJVING
1.	OS60-0265	GREEN PILOT LAMP		CONROLE LAMP (GROEN)
2.	OS60-0116	EMERGENCY PUSH BUTTON		NOOD STOP KNOP
3.	OS60-0098	BEEPER		DAALZOEMER 24V (GELIJKSTROOM)
4.	OS60-0069	FINISHING		BUITENWERK HOOFDSCHAKELAAR
5.	OS61-0034	PRINTCIRCUITBOARD T06		PRINTCIRCUITBOARD T06
6.	OS60-0133	AIR ELECTRIC KABEL		ELEK.KABEL AIR
7.	OS60-0114	NEUTRAL PUSH BUTTON		MONTAGEPLAAT
8.	OS60-0141	TRNSFORMER		TRANSFORMATOR 100VA
9.	OS60-0243	BUTTON WITH ARROW		PIJL (TBV DRUKKNOP OS60-0114)
10.	FSD7985M4X20	SOCKED HEAD SCREW		INBUSBOUT
11.	OS10-173	MOUNTINGPLATE CONTROLBOX		MONTAGE PLAAT (BED.KAST)
12.	OS60-0123	RELAIS 24V DC		RELAIS 24V DC
13.	OS60-0093	LAMP 30V 2W		LAMP 30V 2W (BAJONET)
14.	OS61-0001	DISCONNECTOR WITH CABLE		BINNENWERK HFD.SCHAKELAAR
15.	FND934M4	NUT		MOER
16.	OS61-0003	MOTOR CABLE FULGOR		ELEK.KABEL MOTOR/MAGN.SCH
17.	OS61-0004	LEVELLING SYSTEM ELECTRIC CABLE		ELEK.KABEL SYNCH.SENSOR P1
18.	OS61-0005	PRESSURE ELECTRIC CABLE		ELEK.KABEL SYNCH.SENSOR P2
19.	OS61-0006	ADJ.LOWERING ELECTRIC CABLE		ELEK.KABEL ZAKVENTIEL1
20.	OS61-0007	DISCHARGED ELECTRIC CABLE		ELEK.KABEL DISCHARGE
21.	OS61-0008	LEVELLING ELECTRIC CABLE LIFT TABLE		ELEK.KABEL SYNCH.VENTIEL1
22.	OS61-0009	UP/DOWN ELECTRIC CABLE LIFT TABLE		ELEK.KABEL SYNCH.VENTIEL2
23.	OS61-0010	AIR ELECTRIC CABLE		ELEK.KABEL AIR
24.	OS61-0002	BUTTONS CABLE		ELEK.KABEL BUTTON

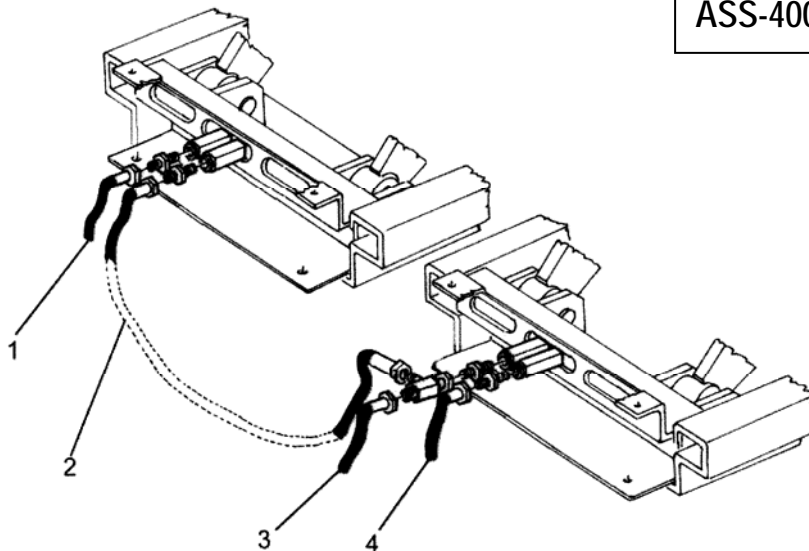

ASS-4009 ASS-4009/T	ASS-5009 ASS-5009/T
------------------------	------------------------

POS	BESTEL NUMMER ORDER NUMBER BESTELLUNGSNUM	DESCRIPTION	BESCHREIBUNG	OMSCHRIJVING
1.	OS40-0254	HOSE L=5400 MM R2 AT 3/8"		HYDR.SLANG R2AT 3/8X5400MM
2.	OS40-0258	HOSE L=2400 MM R2 AT 3/8"		HYDR.SLANG R2AT 3/8X2400MM
3.	OS40-0253	HOSE L=4200 MM R2 AT 3/8"		HYDR.SLANG R2AT 3/8X4200MM
4.	OS40-0255	HOSE L=3900 MM R2 AT 1/4"		HYDR.SLANG R2AT 3/8X3900MM

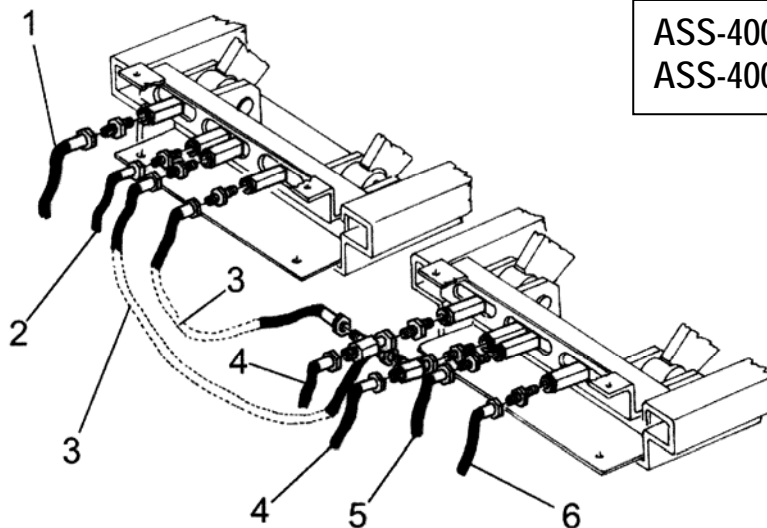

ASS-4009/WF ASS-4009/T/WF	ASS-5009/WF ASS-5009/T/WF
------------------------------	------------------------------

POS	BESTEL NUMMER ORDER NUMBER BESTELLUNGSNUM	DESCRIPTION	BESCHREIBUNG	OMSCHRIJVING
1.	OS40-0254	HOSE L=5400 MM R2 AT 3/8"		HYDR.SLANG R2AT 3/8X5400MM
2.	OS40-0257	HOSE L=5700 MM R1 AT 3/8"		HYDR.SLANG R1AT 3/8X5700MM
3.	OS40-0258	HOSE L=2400 MM R2 AT 3/8"		HYDR.SLANG R2AT 3/8X2400MM
4.	OS40-0256	HOSE L=4200 MM R2 AT 1/4"		HYDR.SLANG R2AT 1/4X4200MM
5.	OS40-0253	HOSE L=4200 MM R2 AT 3/8"		HYDR.SLANG R2AT 3/8X4200MM
6.	OS40-0255	HOSE L=3900 MM R2 AT 3/8"		HYDR.SLANG R2AT 3/8X3900MM